



Unit II

Vehicle Suspension Systems

By,
Mr. A J Bhosale
Asst. Professor
Dept. of Automobile Engineering
Govt. College of Engineering and Research, Avsari (Kd)



❖ Syllabus:

Road irregularities and need of suspension system, Types of suspension system, Sprung and unsprung mass, Suspension springs – requirements, types and characteristics of leaf spring, coils spring, rubber spring, air and torsion bar springs, Independent suspension for front and rear, Types, Hydro-elastic suspension, Roll centre, Use of anti-roll bar and stabilizer bar, Shock absorbers – need, operating principles and types, Active suspension.



❖ Road irregularities:

- The daily use of the road infrastructure, continuous changes of weather conditions, and vehicle's overweight will produce different road surface wearing pattern.
- In addition, deficient road construction process will eventually lead to road surface irregularities.
- Nearly 20% accidents are triggered by infrastructure's condition.
- Potholes, road cracks, unevenness and different friction levels can promote accidents due to emergency maneuvers.





❖ Need of Suspension:

1. For absorbing shocks and vibration caused due to road irregularities.
2. For transmitting vehicle load to the wheels (Supporting the weight)
3. For maintaining the stability of vehicle (contact of the wheels to ground)
4. For providing cushioning and ride comfort to the passengers
5. For preventing body squat and body dive.

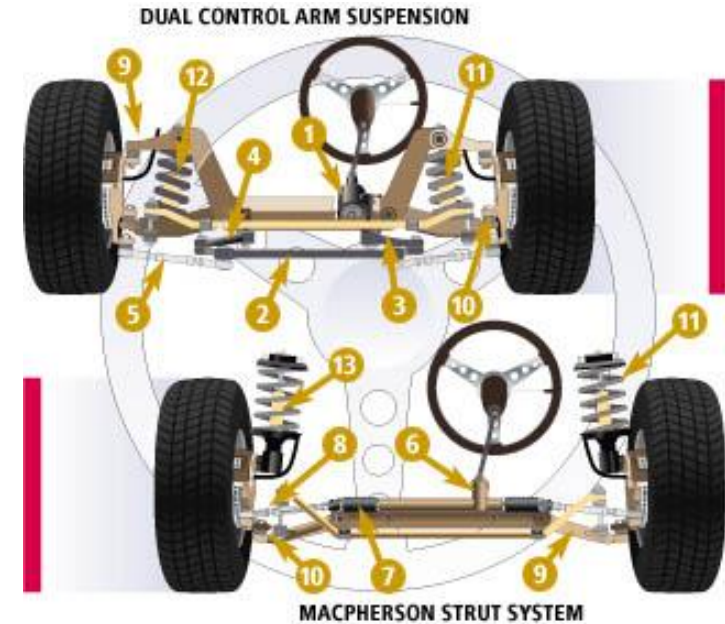



Functions:

- To safe guard passengers and goods against road shocks
- To preserve the stability of vehicles while in motion (Pitching or Rolling)
- To provide the wheels always in contact with road while driving cornering and braking
- To maintain proper steering geometry
- To provide suitable riding and cushioning properties
- To Allow rapid cornering without extreme body roll
- To prevent excessive **body squat** or **body dive**.

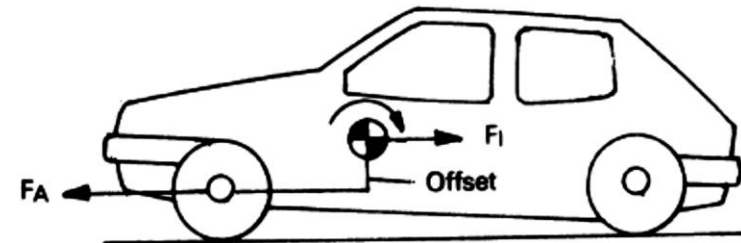

(a) Acceleration squat

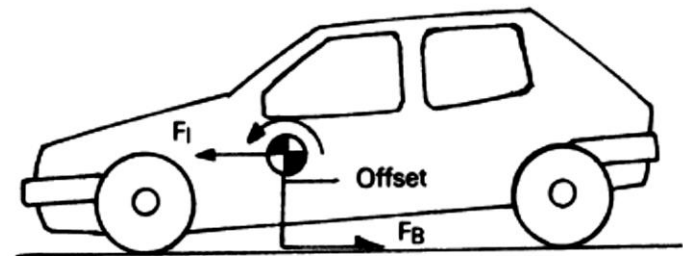

(b) Braking dive

Fig. 10.61 (a and b) Vehicle squat and dive



❖ Requirements:

1. There should be minimum deflection.
2. It should be of low initial cost.
3. It should be of minimum weight.
4. It should have low maintenance and low operating cost.
5. It should have minimum tyre wear.



❖ Vehicle Axis System:

Rotations:

- A roll rotation about x-axis
- A pitch rotation about y-axis.
- A yaw rotation about z-axis

Basic suspension movements:

1. Bouncing: The vertical movement of the complete body.
2. Pitching: The rotating movement of all the parts between the spring and road and the portion of spring weight itself.
3. Rolling: The movement about longitudinal axis produced by the centrifugal force during cornering.

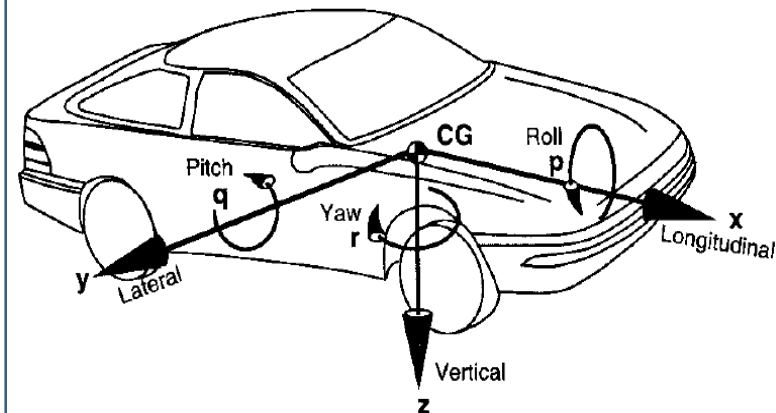



❖ Sprung and Un-sprung Masses:-

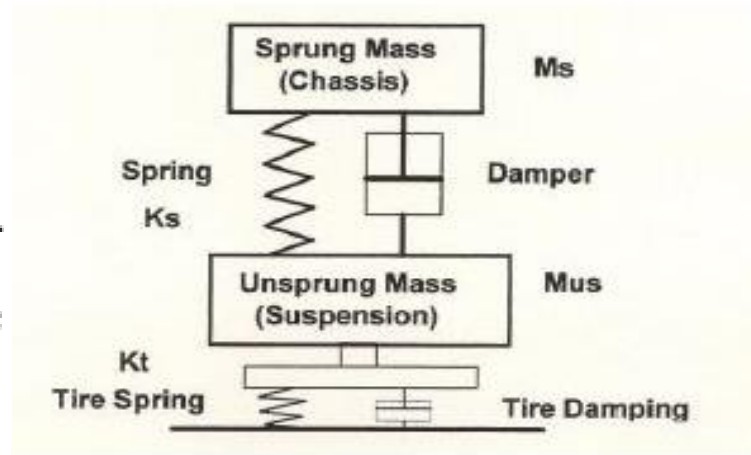
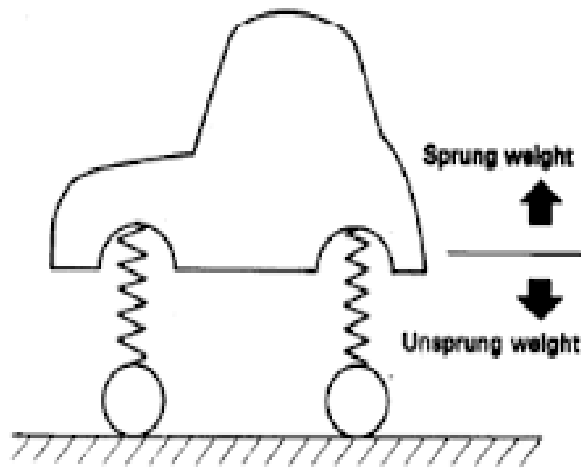



❖ Sprung Mass:

- In a vehicle with a suspension, such as an automobile, motorcycle or a tank, sprung mass (or sprung weight) is the portion of the vehicle's total mass that is supported above the suspension.
- The sprung weight typically includes the body, frame, the internal components, passengers, and cargo but does not include the mass of the components suspended below the suspension components (including the wheels, wheel bearings, brake rotors, callipers)

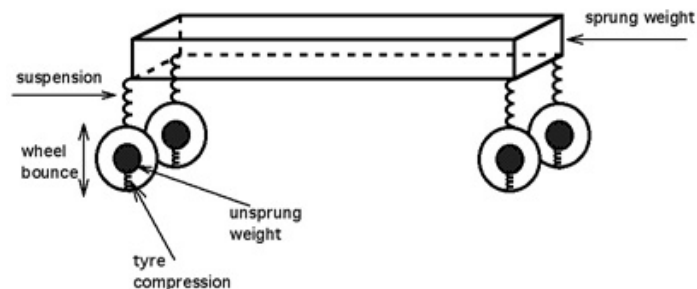



❖ Un-sprung Mass:

- In a ground vehicle with a suspension, the un-sprung weight (or the un-sprung mass) is the mass of the suspension, wheels or tracks (as applicable), and other components directly connected to them, rather than supported by the suspension.
- Un-sprung weight includes the mass of components such as the wheel axles, wheel bearings, wheel hubs, tires, and a portion of the weight of drive shafts, springs, shock absorbers, and suspension links.



❖ Types of Suspension:

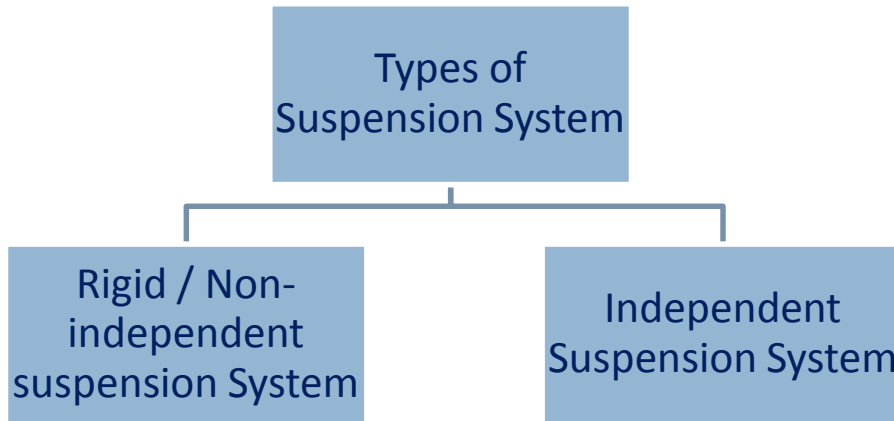

LOW SPEED BUMP WITH THE PATENTED LEHMAN "NO LEAN SUSPENSION"

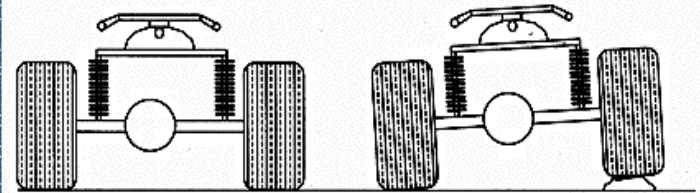

LOW SPEED BUMP WITH INDEPENDENT SUSPENSION

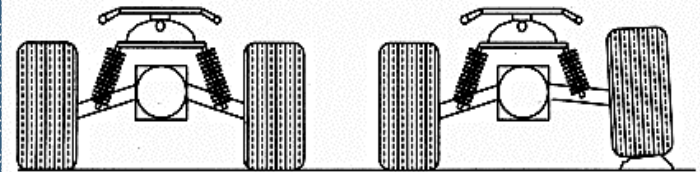



TYPES OF SUSPENSION SYSTEM

SPRINGS

1. Steel springs

- Leaf spring
- Tapered leaf spring
- Coil spring
- Torsion bar

2. Rubber springs

- Compression spring
- Compression-shear spring
- Steel-reinforced spring
- Progressive spring
- Face-shear spring
- Torsional shear spring

INDEPENDENT SUSPENSION

FRONT WHEEL(DEAD)

- Wishbone or parallel link type
- Mac-Pherson strut type
- Vertical guide type
- Trailing link type
- Swinging half-axle type

SHOCK ABSORBERS

- Telescopic
- Lever arm type

HYDROLASTIC SUSPENSION

STABILIZER OR ANTI-ROLL BAR

AIR OR PNEUMATIC SUSPENSION

AIR SPRING

- Bellow type
- Piston type



1. Non-independent/Rigid suspension has

both right and left wheel attached to the same solid axle. When one wheel hits a bump in the road, its upward movement causes a slight tilt of the other wheel.

2. Independent suspension allows one wheel to move up and down with minimal effect to the other.

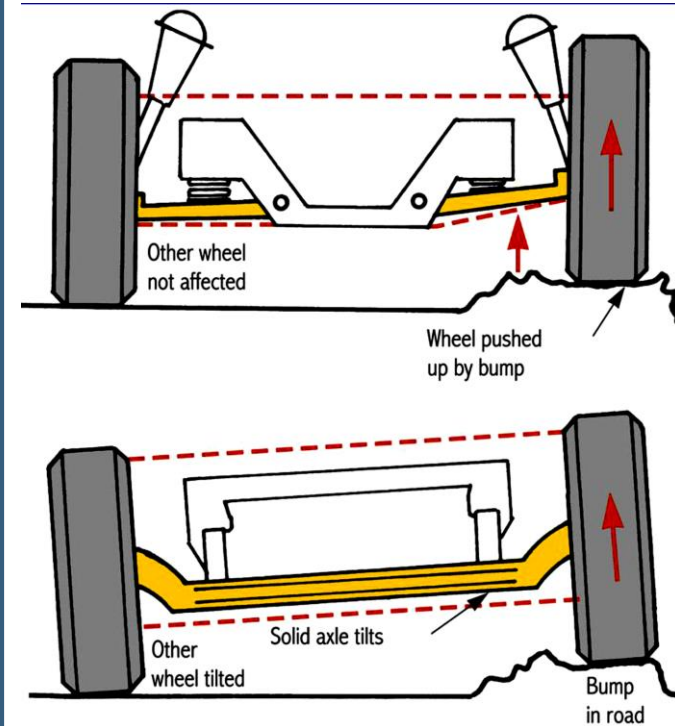



❖ Components of Suspension System:

- Springs, which neutralize the shocks from the road surface (Energy storage)
- Dampers, which act to improve comfort by limiting the free oscillation of the springs. (Energy Dissipation)
- Stabilizer (sway bar or anti-roll bar), which prevents lateral swaying of the car.
- A linkage system, which acts to hold the above components in place and the control the longitudinal and lateral movements of the wheels.

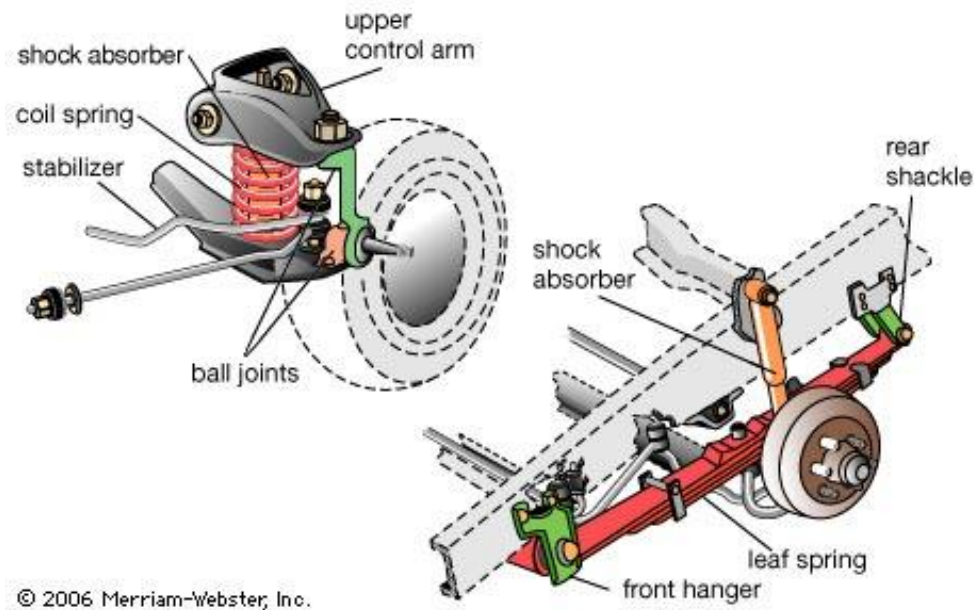

Coil spring is the most common type of spring found on modern vehicles.

Leaf springs are now limited to the rear of some cars.



❖ Leaf Springs:

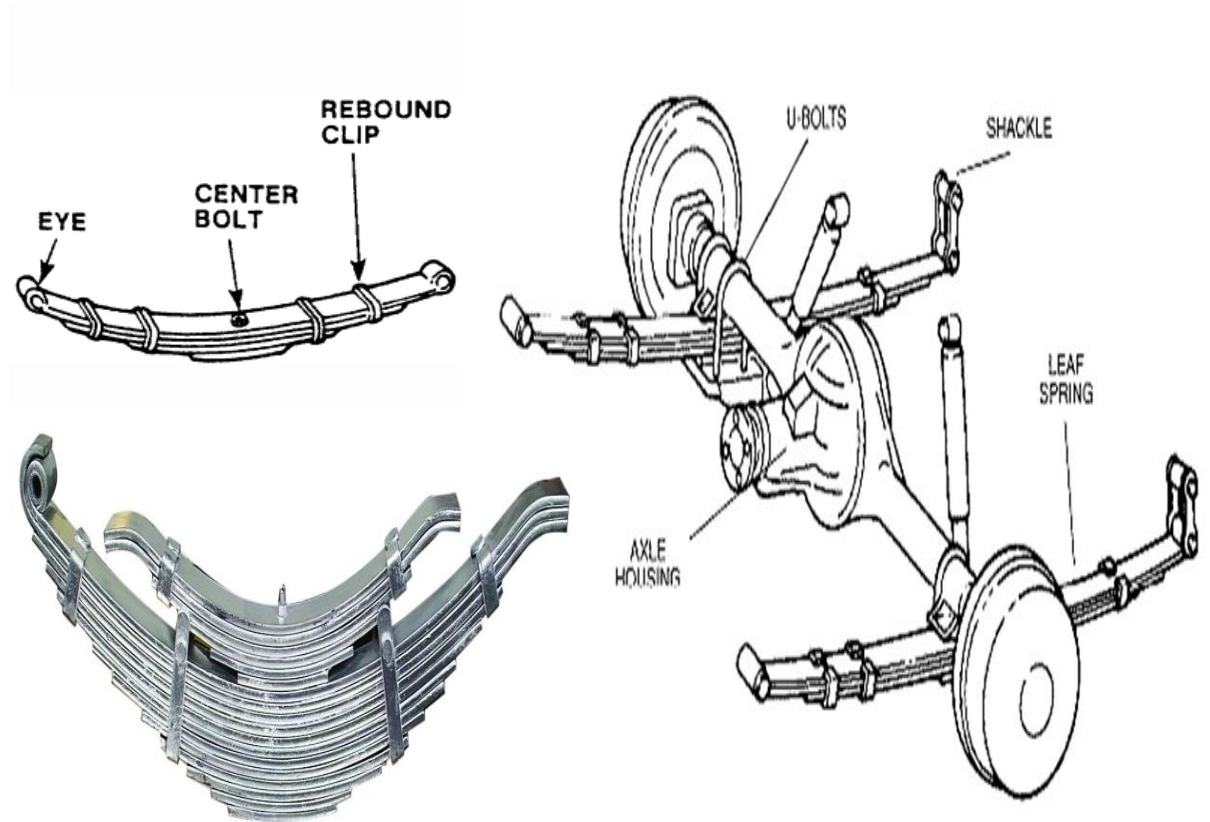



Forces and Moments acting on Leaf Spring:

1. Vertical force caused by vehicle laden weight.
2. Longitudinal forces caused by tractive and braking effort.
3. Transverse forces caused by centrifugal force, side slopes, lateral winds.
4. Rotational torque reaction caused by driving and braking efforts.



Material Used for Leaf Springs

The suitable steels that have been used for the leaf springs are given below :

1. Chrome-vanadium steel

<i>Constituents</i>	<i>Percentage</i>
C	0.46
Mn	0.57
Si	0.17
Ni	0.15
Cr	1.40
Va	0.18

2. Silico-Manganese Steel

<i>Constituents</i>	<i>Percentage</i>
C	0.52
Mn	1.05
Si	1.95
Cr	0.05

3. Carbon Steel

<i>Constituents</i>	<i>Percentage</i>
C	0.55
Mn	0.60
Si	0.20



❖ Leaf Spring

- Leaf spring was invented by Obadiah Elliot of London in 18th century. He simply piled one steel plate on top of another, pinned them together and shackled each end to a carriage, it was the first ever leaf spring used on a vehicle.
- It is originally called as a laminated or carriage spring, and sometimes referred to as a semi-elliptical spring or cart spring.

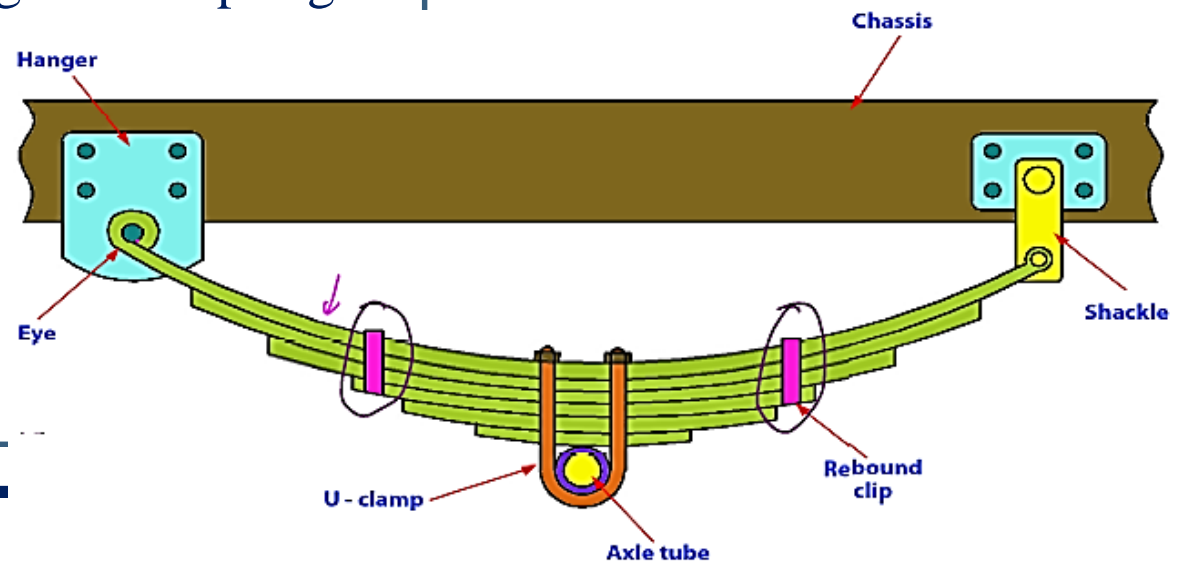
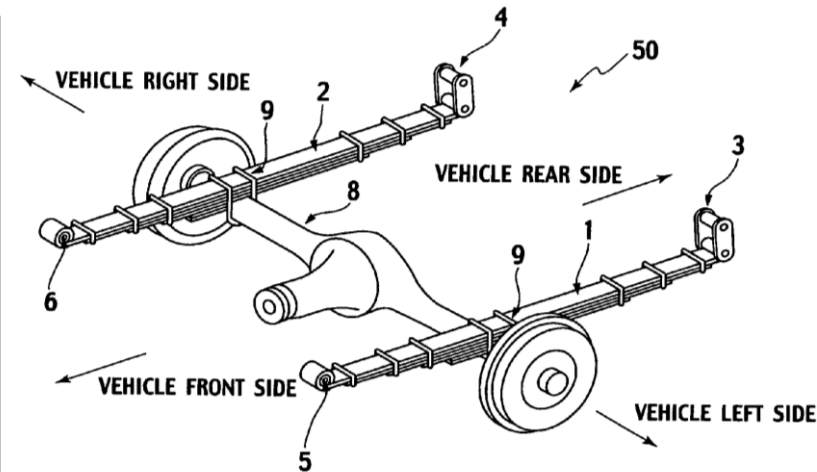



❖ Leaf Springs:

- Leaf springs are formed by bending.
- They are made of long strips of steel.
- Each strip is named as Leaf.
- The long leaf is called Master Leaf, and it consists of eyes at its both ends.
- One end is fixed to the chassis frame, the other end is fixed to the shackle spring.
- The spring will get elongated during expansion and shortened during compression.
- This change in length of spring is compensated by the shackle.
- The U-bolt and clamps are located at the intermediate position of the spring.
- The bronze or rubber bushes are provided on both eyes on the master leaf.

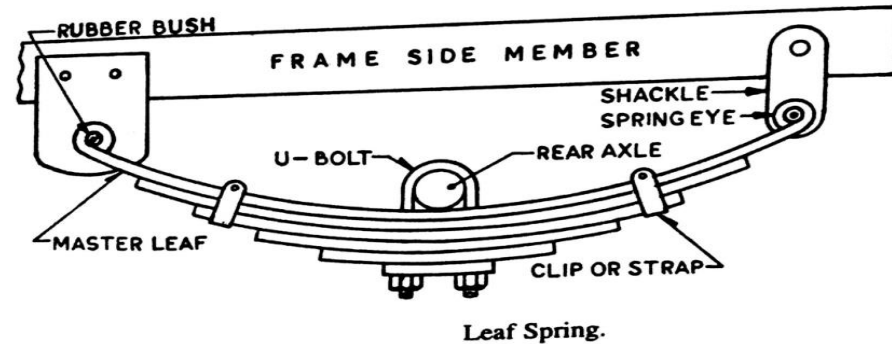







❖ Types:

There are six types of leaf springs

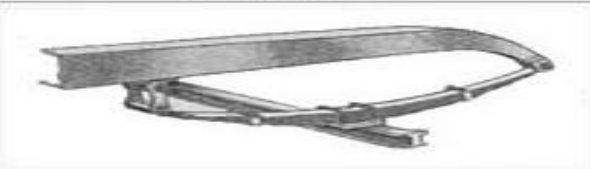
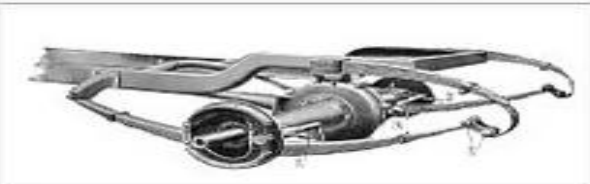
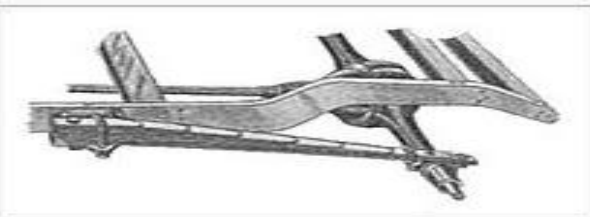
1. Full – elliptic type
2. Semi – elliptic type
3. Quarter – elliptic type
4. Three Quarter – elliptic type
5. Transverse Spring type
6. Helper Spring type

Elliptic	
Semi-elliptic	
Three quarter-elliptic	
Quarter-elliptic	
Transverse	



1. Full – elliptic

- The advantage of this type is the elimination of shackle and spring.
- The lubrication and wear frequently which are on of the main draw back of this type of springs



2. Semi – elliptic

- Mostly used in Trucks, buses (for rear and front Suspension) and in some cars (for rear suspension)

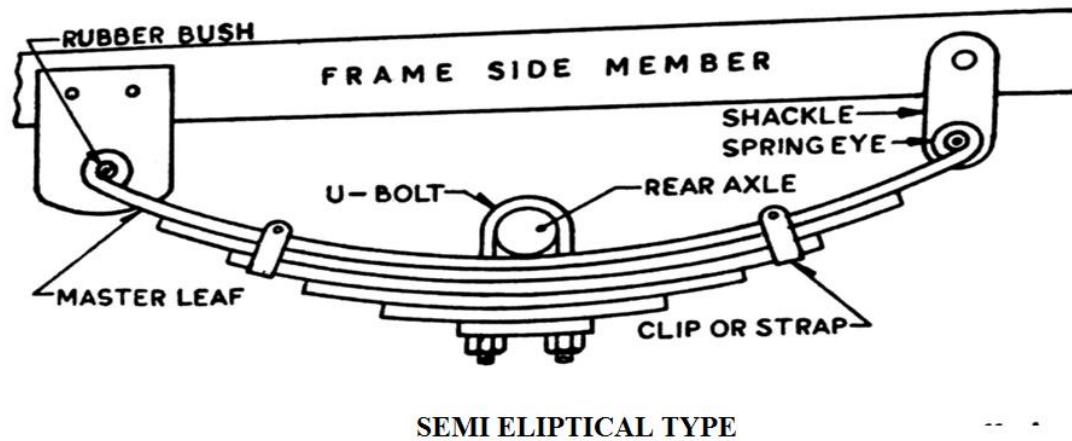



3. Quarter – elliptic

- This type is rarely used in now-a-days.
- It gives very less resistance in road shocks.

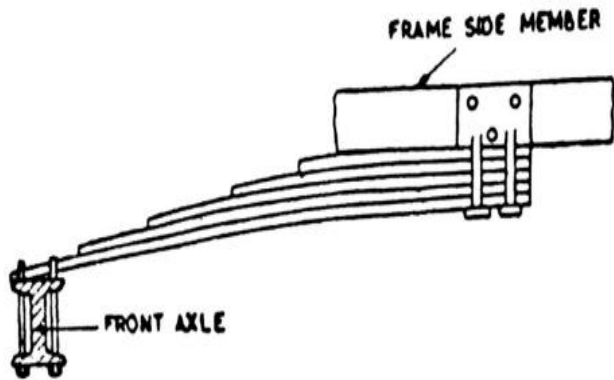
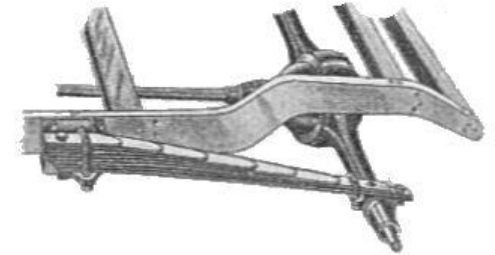



4. Three Quarter – elliptic

- This type is rarely used in now-a-days.
- It gives good resistance to shocks, but occupies more space than other types.

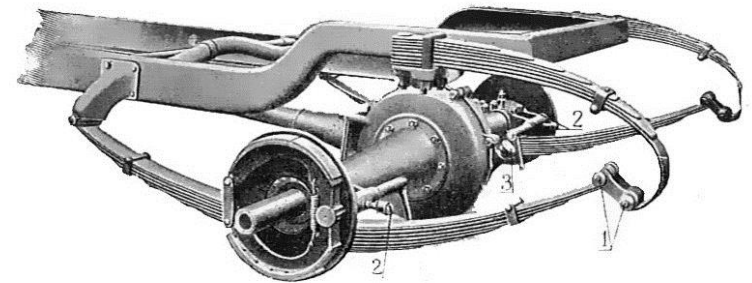
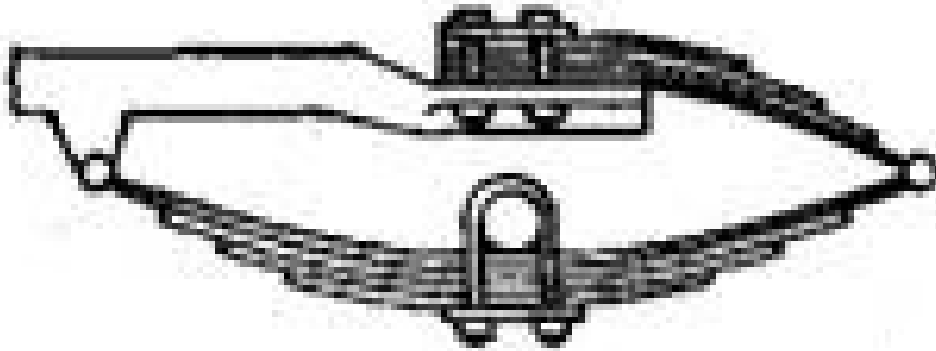



5. Transverse Spring

- This type of spring is arranged transversely across the vehicle instead of longitudinal direction.
- The transverse spring for front axle, which is bolted rigidly to the frame at the centre and attached to the axle by means of shackle at both ends.
- Disadvantage of this spring is that the vehicle body in this case is attached to the springs at only two places, which imparts the vehicle a tendency to roll easily when it runs fast on sharp corners.

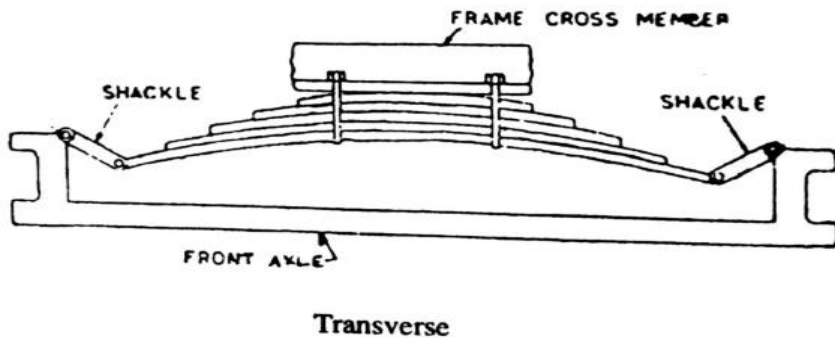



6. Helper Spring

- Helper spring are provided on many commercial vehicles in addition to the main leaf springs.
- They allow wide range of loading. When the vehicle is lightly loaded, these helper springs do not come into operation.
- But as load is increased, they take their share of load.
- Generally helper springs are used on rear suspension.

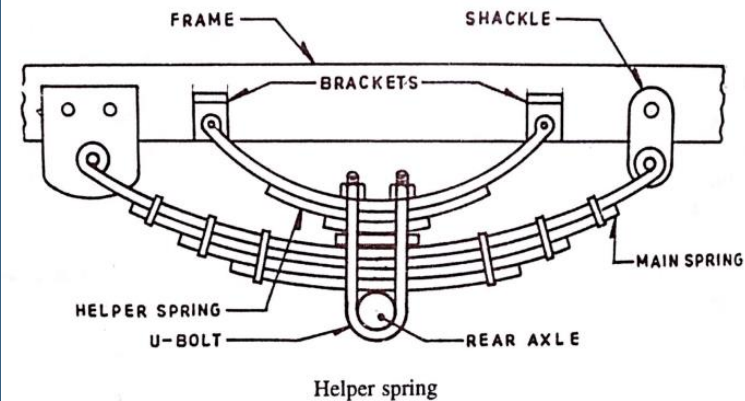



Taperlite Spring

English Steel Corporation Ltd. of England has produced 'Taperlite' springs, which have the following advantages over the conventional leaf springs due to which these are becoming increasingly popular compared to constant-section conventional leaf springs.

1. Light weight—Nearly 60% of the corresponding conventional spring.
2. There is no interleaf friction in case of single taper leaf spring.
3. Absence of squeaking.
4. The stresses are lower and more uniform compared to the conventional springs, thus giving longer life.
5. They occupy less space.
6. In case of single taper leaf spring, there is no collection of moisture between the leaves



Taperlite spring

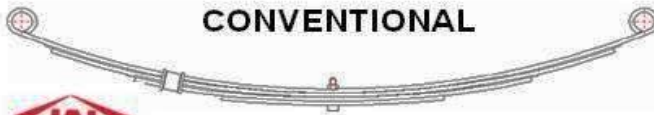

CONVENTIONAL

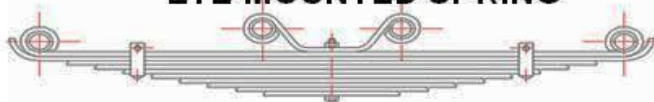

EYE MOUNTED SPRING

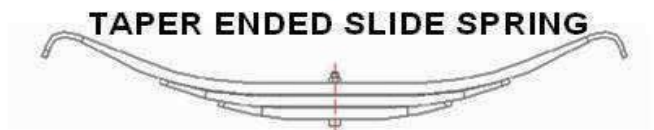

TAPER ENDED SLIDE SPRING



PROGRESSIVE SPRING

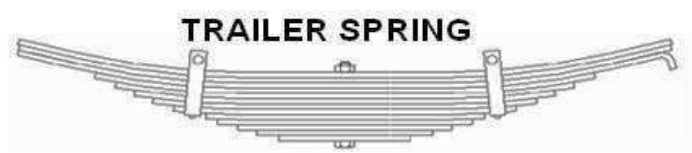

TRAILER SPRING

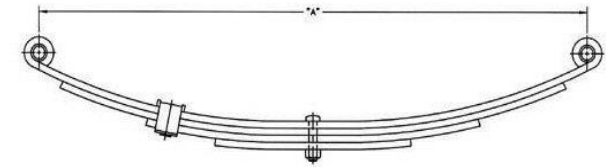

DOUBLE EYE LEAF SPRINGS

Measure Mounting Point To Mounting Point Center

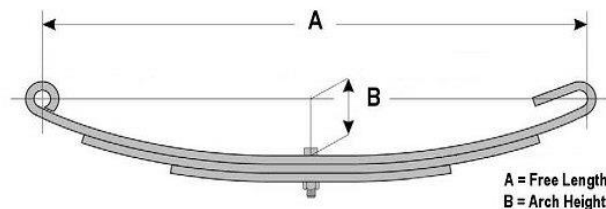

OPEN EYE LEAF SPRINGS

Measure Mounting Point to Furthest Inside Point

A = Free Length
B = Arch Height

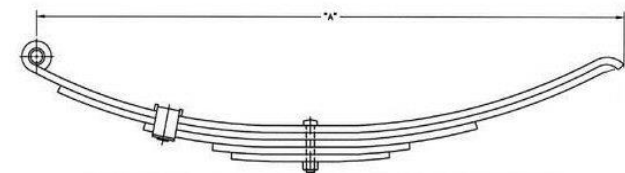

HOOK END, FLAT END & RADIUS END SPRINGS

Measure Front Bolt To End Of Spring

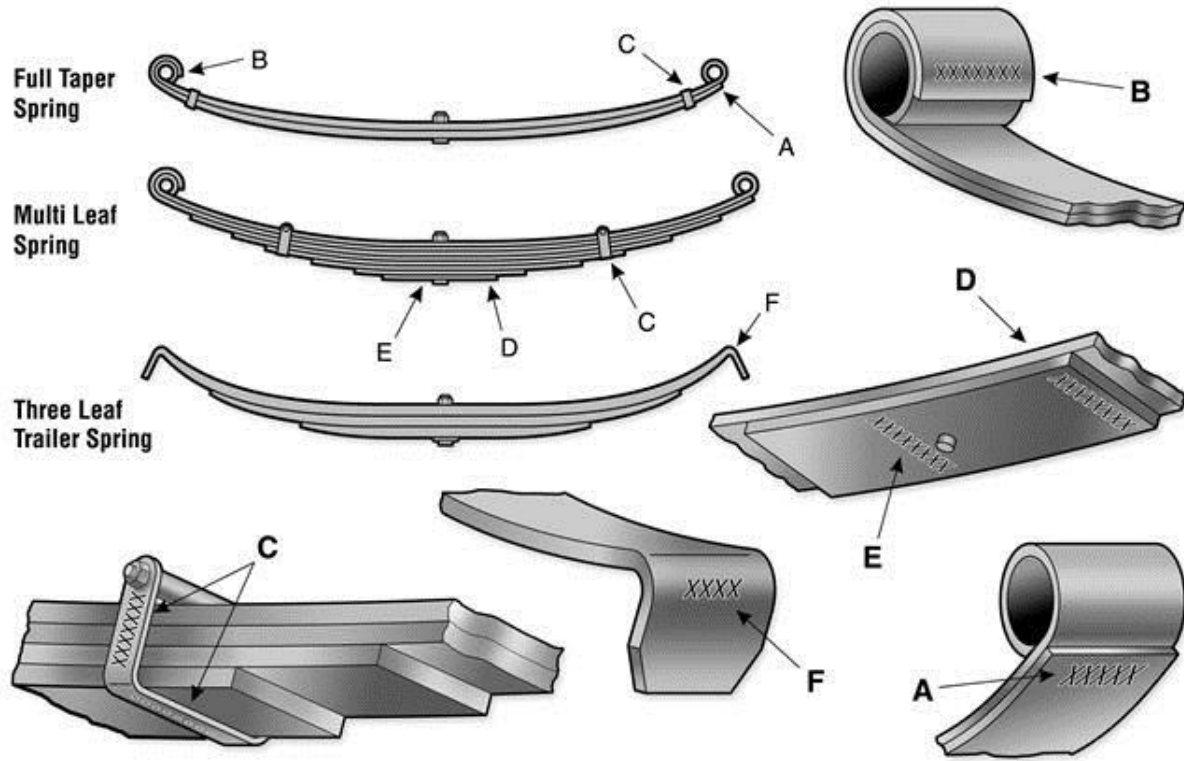

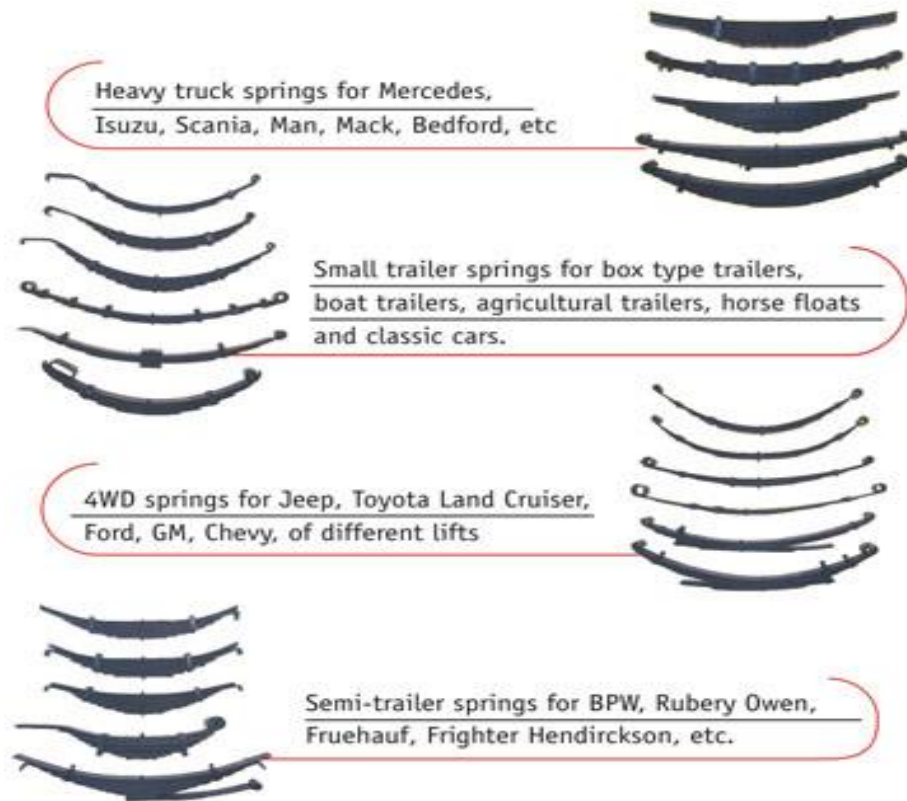



❖ Manufacturing Process

1. Shearing of flat bar
2. Center hole punching / Drilling
3. End heating process forming
 - Eye Forming / Wrapper Forming
 - Diamond cutting / end trimming / width cutting / end tapering
 - End punching / end grooving / end bending / end forging / eye grinding
 - Center hole punching / Drilling / nibbing
4. Heat Treatment
 - Heating
 - Chamber forming
 - Hardening
 - Quenching
 - Tempering



5. Surface preparation

- Shot peening / Stress peening
- Primary painting

6. Eye bush preparation process

- Eye reaming / eye boring
- Bush insertion
- Bush reaming

7. Assemble

- Presetting & load testing
- Finish painting
- Marking & packing

❖ Characteristics of Leaf Spring

- Leaf spring acts as a linkage for holding the axle in position and thus separate linkage are not necessary. It makes the construction of the suspension simple and strong.
- As the positioning of the axle is carried out by the leaf springs so it makes it disadvantageous to use soft springs i.e. a spring with low spring constant.
- Therefore, this type of suspension does not provide good riding comfort.
- The inter-leaf friction between the leaf springs affects the riding comfort.
- Acceleration and braking torque cause wind-up and vibration. Also wind-up causes rear-end squat and nose-diving.

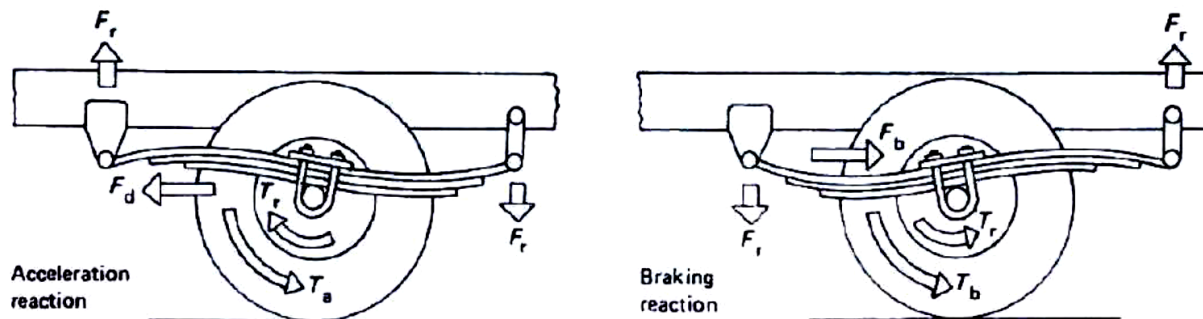

Acceleration and braking reaction forces acting on the spring shackles

F_d – Driving force, F_r – Reaction force, F_b – Braking force,
 T_r – Reaction Torque, T_b – Braking torque, T_a – Acceleration Torque



❖ Coil Springs:

- Coil springs are made of special round spring steel wrapped in a helix shape.
- The strength and handling characteristics of a coil spring depend on the following.
 1. Coil diameter
 2. Number of coils
 3. Height of spring
 4. Diameter of the steel coil that forms the spring
- The larger the diameter of the steel, the “stiffer” the spring.
- The shorter the height of the spring, the stiffer the spring.
- The fewer the coils, the stiffer the spring.

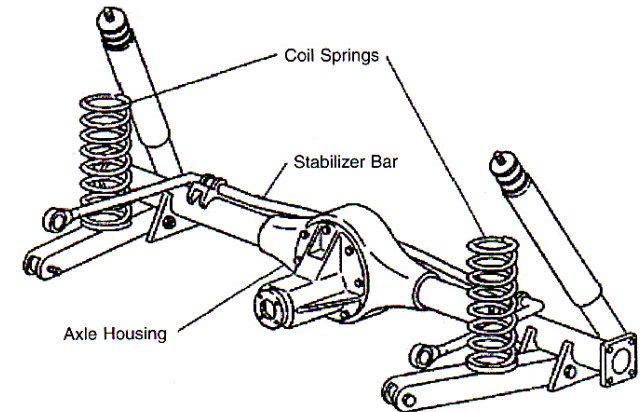
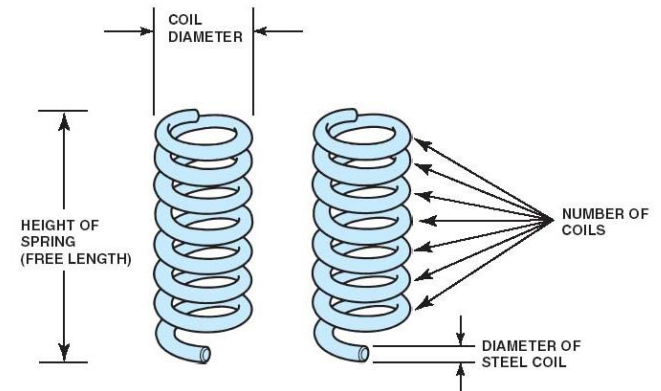

Figure 8.19. A coil spring suspension. Adapted from TM 9-8000 (1985).



The spring rate of a coil spring is determined by the diameter of the spring and the diameter of the steel used in its free length (height). (Courtesy of Moog)



- The coil springs are used mainly with independent suspension, though they have also been used in the conventional rigid axle suspension as they can be well accommodated in restricted spaces.
- The energy stored per unit volume is almost double in the case of coil springs than the leaf springs.
- Coil springs do not have noise problems nor do they have static friction
- Coil springs can take the shear as well as bending stresses.
- The coil springs however cannot take torque reaction and side thrust for which alternative arrangements have to be provided.
- A helper coil spring is also sometimes used to provide progressive stiffness against increasing load.

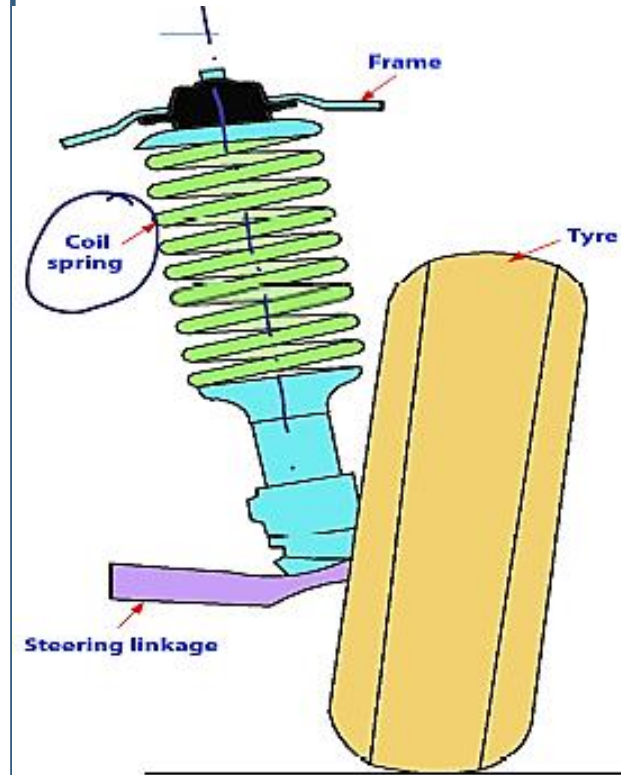



- Springs are designed to provide desired ride and handling and come in a variety of spring ends.

COIL SPRING ENDS

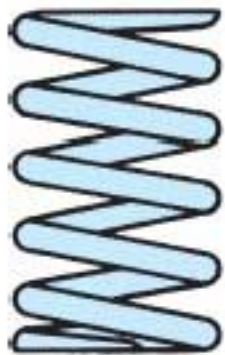

TAPERED
END

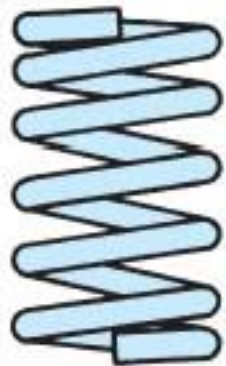

TANGENTIAL
END



PIG -
TAIL

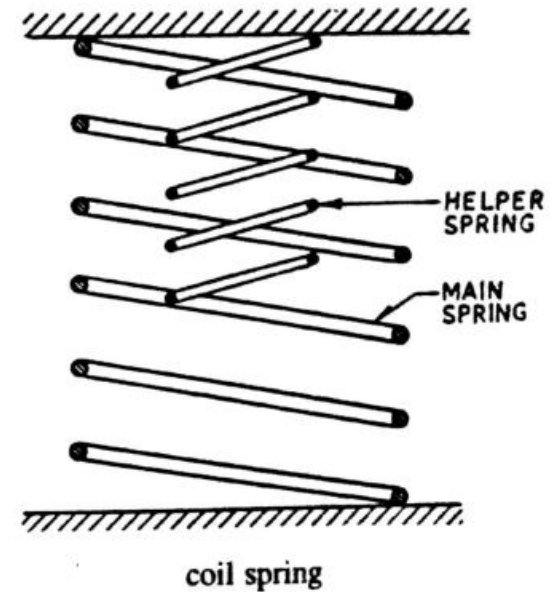

FIGURE 5-10
of suspension designs.

Coil spring ends are shaped to fit the needs of a variety



❖ Spring Rate

- **Spring rate**, also called **deflection rate**, is a value that reflects how much weight it takes to compress a spring a certain amount.
- The spring rate (or stiffness or spring constant) is defined as the load required per unit deflection of the spring. Mathematically

$$k = W / \delta$$

W = Load, and

δ = Deflection of the spring.



- A **constant-rate spring** continues to compress at the same rate throughout its complete range of deflection.
- A **variable-rate spring** may compress one inch under a 100-pound load, but only compress an additional half an inch under a 200-pound load.

CONSTANT-RATE SPRING

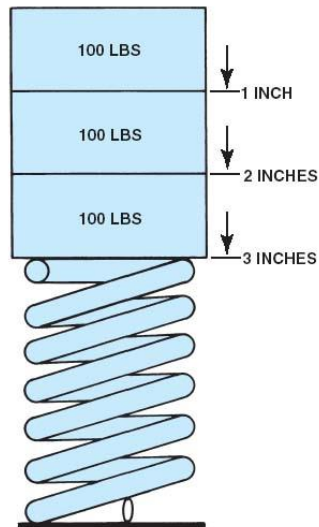

FIGURE 5-11 A constant-rate spring compresses at the same rate regardless of the amount of weight that is applied.

VARIABLE RATE SPRINGS

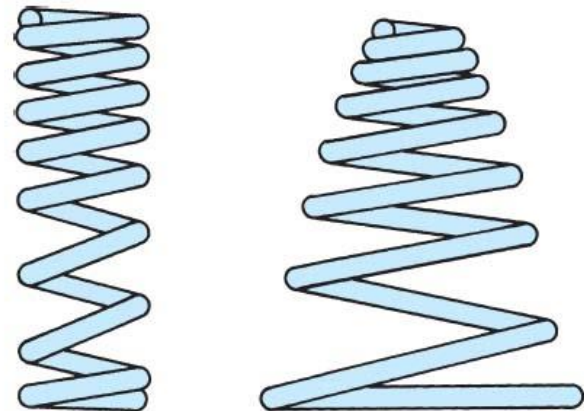

FIGURE 5-12 Variable-rate springs come in a variety of shapes and compress more slowly as weight is applied.

- Before a spring is installed on a vehicle or any load is placed on it, it is at its **uncompressed length**, or free length. Once installed, the weight of the corner of the vehicle resting on the spring is called its **static load**.

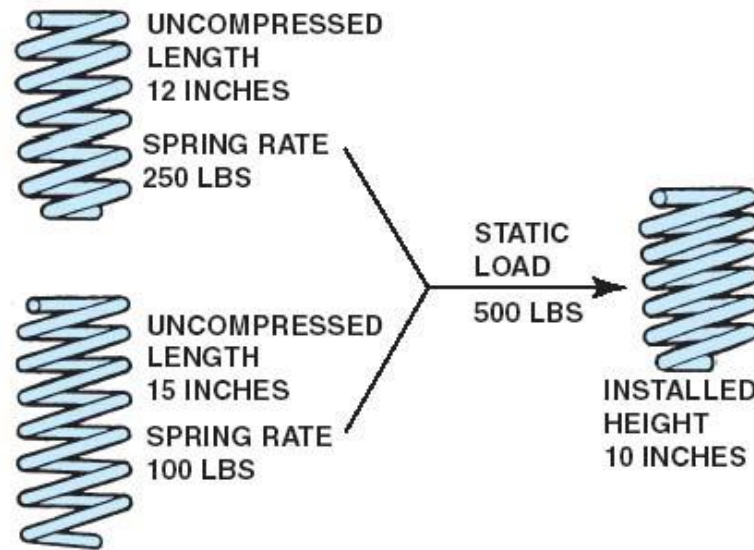

FIGURE 5-13 Two springs, each with a different spring rate and length, can provide the same ride height even though the higher-rate spring will give a stiffer ride.



❖ Coil Spring Mounting

- Coil springs are usually installed in a **spring pocket** or **spring seat**. Hard rubber or plastic **cushions** or **insulators** are usually mounted between the coil spring and the spring seat.

❖ Spring Coatings

- All springs are painted or coated with epoxy to help prevent breakage. A scratch, nick or pit caused by corrosion can cause a **stress riser** that can lead to spring failure.

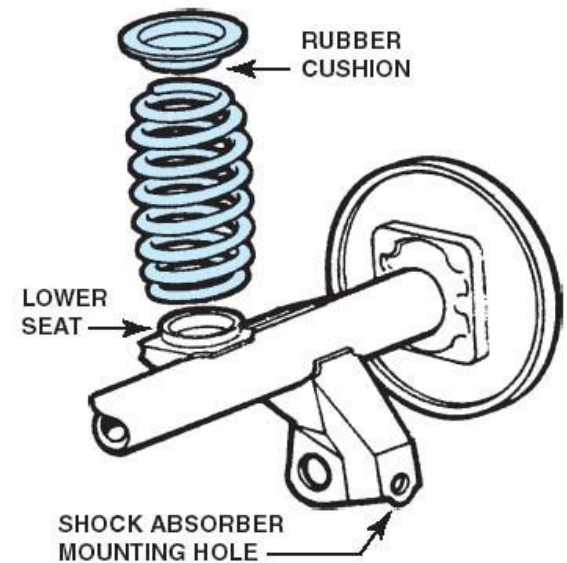

FIGURE 5-16 The spring cushion helps isolate noise and vibration from being transferred to the passenger compartment. (Courtesy of Moog)



❖ Rubber Springs

- As rubber can store more energy per unit mass than any other type of spring material, considerable weight can be saved with rubber suspension.
- It is more compact than other springs.
- It has also excellent vibration damping property.
- One more advantage of using rubber is that it is not suddenly fail like steel so there is less risk.
- First introduced in 1958 by Eric Moulton.





❖ Working:

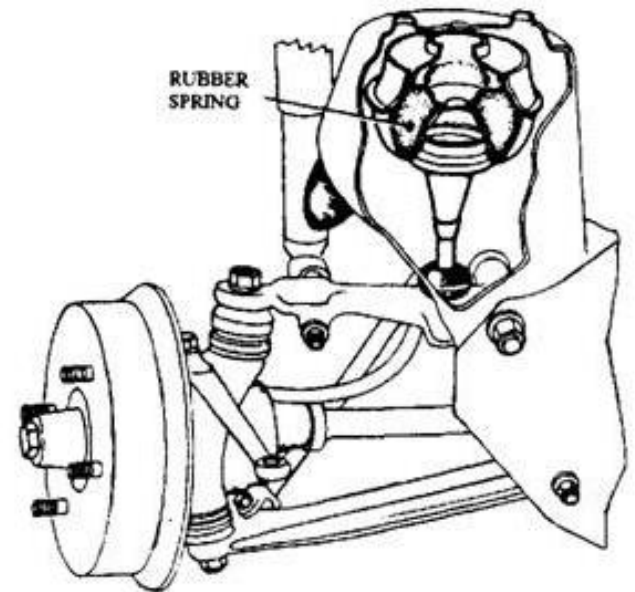
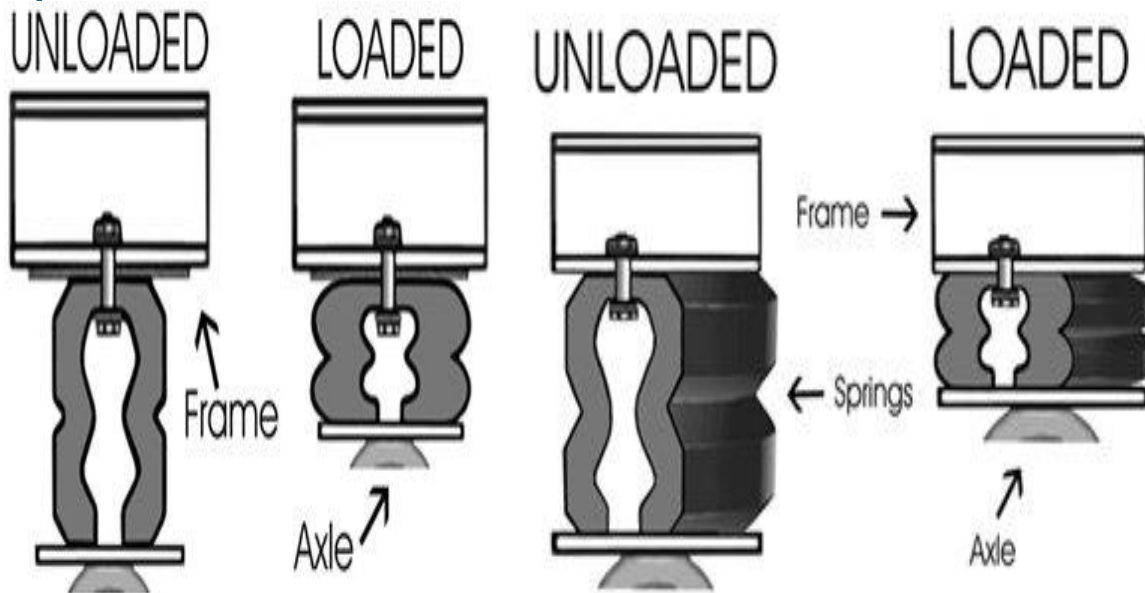



- Fig. represents a rubber suspension system in a simplified form, that is similar to the one used on a popular small car.
- The spring is installed between the frame and the top link of the suspension system.
- When the spring is connected to a point near the link pivot, deflection of the spring reduces to a minimum, without affecting the total wheel movement.
- This arrangement of spring provides a rising-rate characteristic, which is 'soft' for small wheel movements but becomes harder as the spring deflects.
- The energy released from the rubber spring after deflection is considerably less than that imparted to it.
- This internal loss of energy is called hysteresis, which is an advantage, because lower-duty dampers may be used.
- Some rubber suspension systems have a tendency to 'settle down' or 'creep' during the initial stages of service, therefore allowance for this must be provided

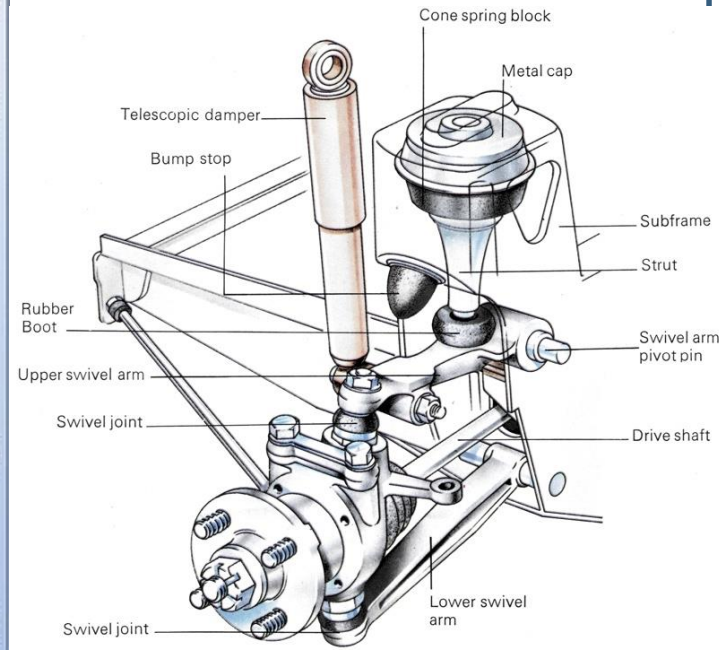
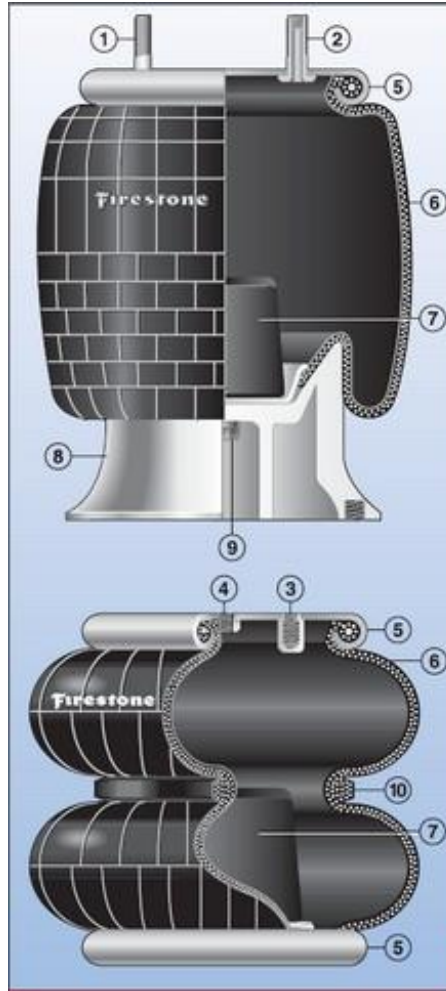



❖ Types:

1. Compression spring
2. Compression-shear spring
3. Steel-reinforced spring





1. Compression Spring

- This type of spring is still being used because of following advantages,
 - It is reliable, of simple construction and requires no bonding.
 - It provides a rising rate characteristics.
 - It can resist occasional overload of large magnitude.
 - It has a large measure of damping than most types of rubber springs.

However, its use is limited because of the fact that some mechanical guide must be provided with this type of spring and the provision of mechanical guide generally undesirable.

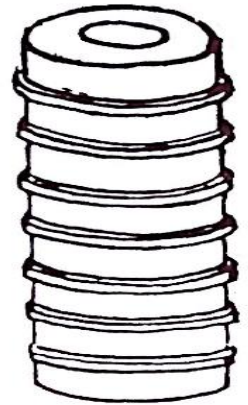

Compression spring.





2. Compression-Shear Spring

- In this type, the load is carried partly by shear and by compression components in the rubber.

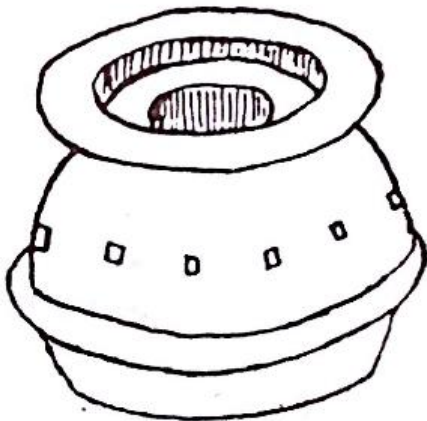

Compression shear spring.





3. Steel-reinforced spring

- Steel reinforced spring (Eligos Spring) consist of a steel helical spring bonded in rubber body.
- The steel spring though carrying only about 20% of the load, exercises a stabilizing influence on the rubber component thereby allowing a greater stroke/diameter ratio to be used without other forms of guiding

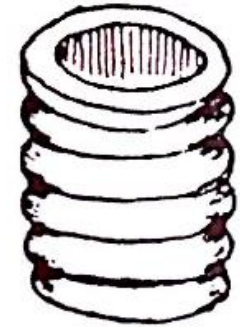

Steel reinforced spring.





❖ Torsion Bars:

- This is a straight bar of circular or square section fixed to the frame at one end, and a lever or wishbone-shaped member connects its other end to the wheel. A torsion bar suspension system used on a car is illustrated in Fig.
- The diameter is increased at each end of the bar and the bar is connected with the levers by serrations. Provision for the adjustment is made at the frame end to 'level' the suspension.
- Since the coil spring is a form of torsion bar, the rate of both springs depends on the length and diameter. The rate decreases or the spring becomes softer if the length is increased or the diameter is decreased.

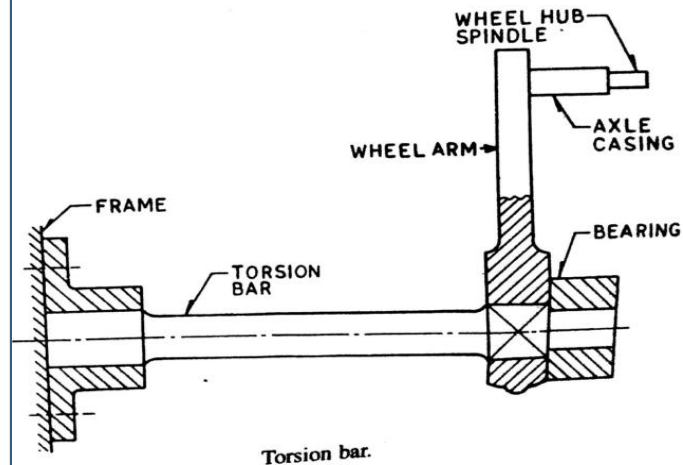
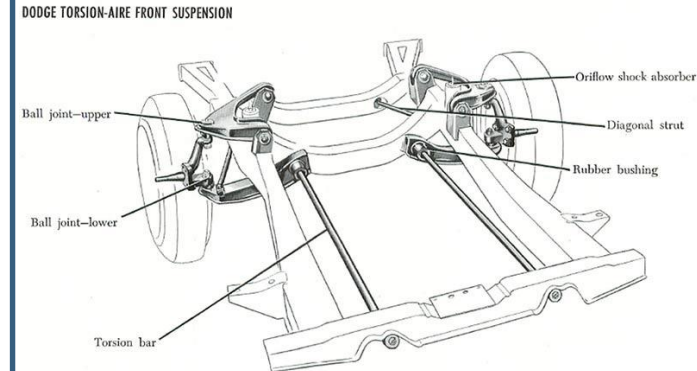

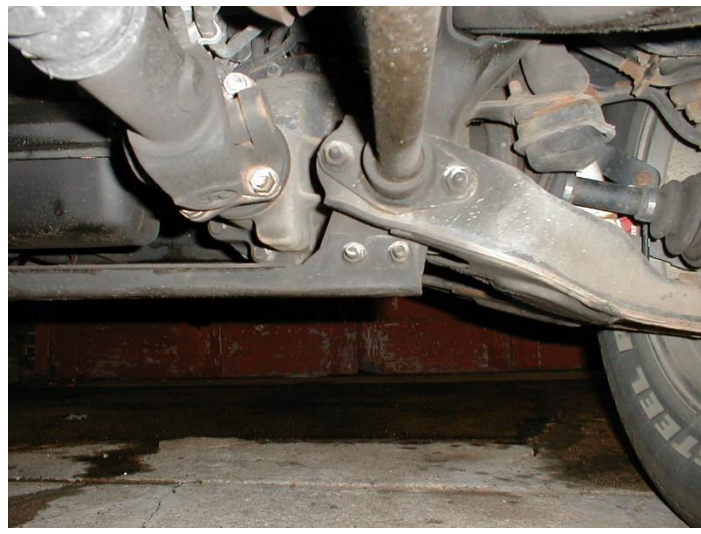
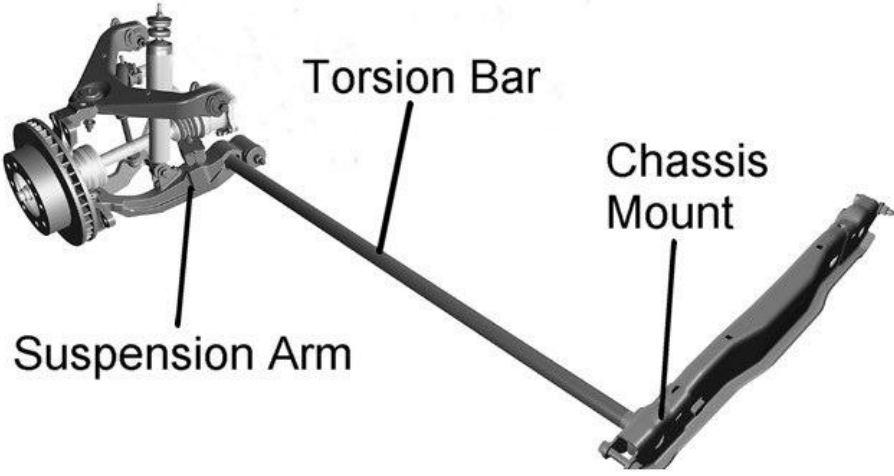
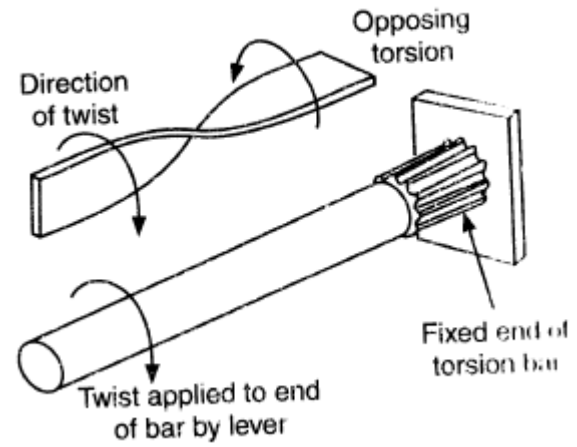
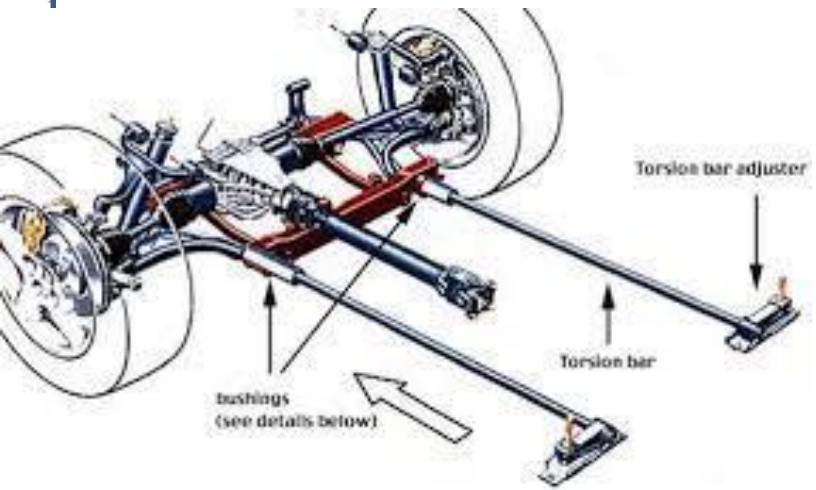

COMPONENTS OF TORSION BAR

Advantages

- Light in weight.
- Less space required.
- Its maintenance cost is less.
- Initial cost is less.
- Ride comfort is more.

Disadvantages

- It does not take acceleration & Braking thrust so required additional linkages
- Lack of friction damping

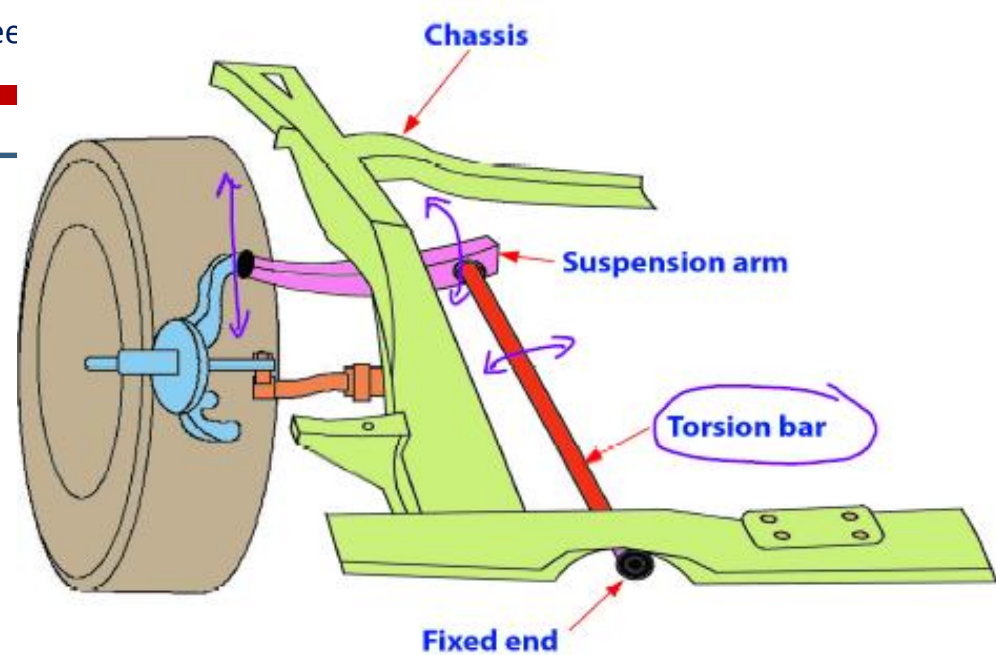



❖ Air Suspension:





❖ History:

- In 1901 an American, William W. Humphreys, patented an idea - a 'Pneumatic Spring for Vehicles.
- From 1920, Frenchman George Messier provided aftermarket pneumatic suspension systems.
- During World War II, the U.S. developed the air suspension for heavy aircraft in order to save weight with compact construction.
- In 1954, Frenchman Paul Magès developed a functioning air/oil hydro-pneumatic suspension, incorporating the advantages of earlier air suspension concepts.
- GM introduced air suspension as standard equipment on the new 1957 Cadillac Eldorado Brougham.
- Dunlop Systems UK were also pioneers of Electronically Controlled Air Suspension (ECAS) for off road vehicles - the term ECAS was successfully trade marked. The system was first fitted to the 93MY Landrover Rangerover.



- Air suspension is used in place of conventional steel springs in passenger cars, and in heavy vehicle applications such as buses and trucks. It is broadly used on semi trailers, trains (primarily passenger trains).
- The purpose of air suspension is to provide a smooth, constant ride quality, but in some cases is used for sports suspension.
- Modern electronically controlled systems in automobiles and light trucks almost always feature self-leveling along with raising and lowering functions.
- Although traditionally called **air bags** or **air bellows**, the correct term is **air spring** (although these terms are also used to describe just the rubber bellows element with its end plates).

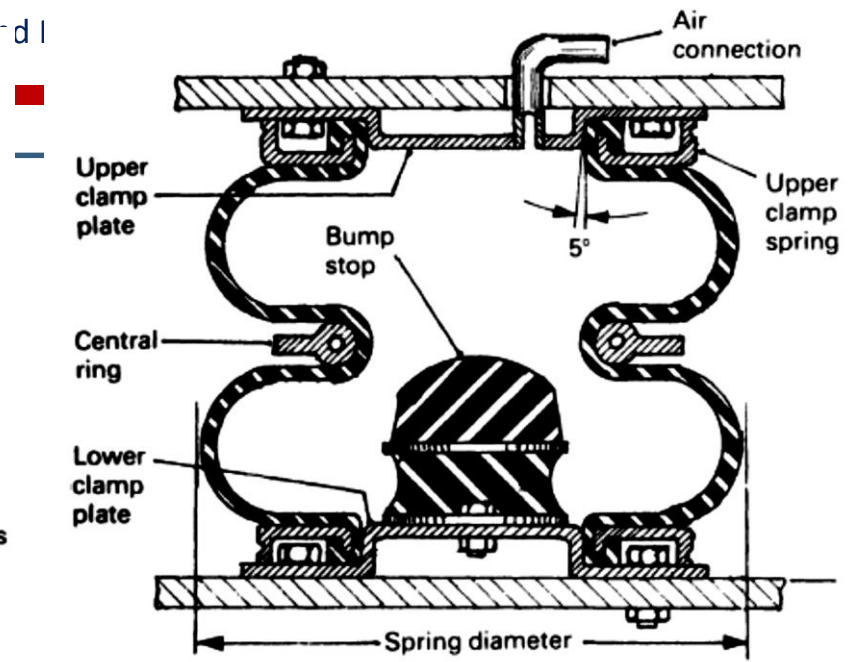
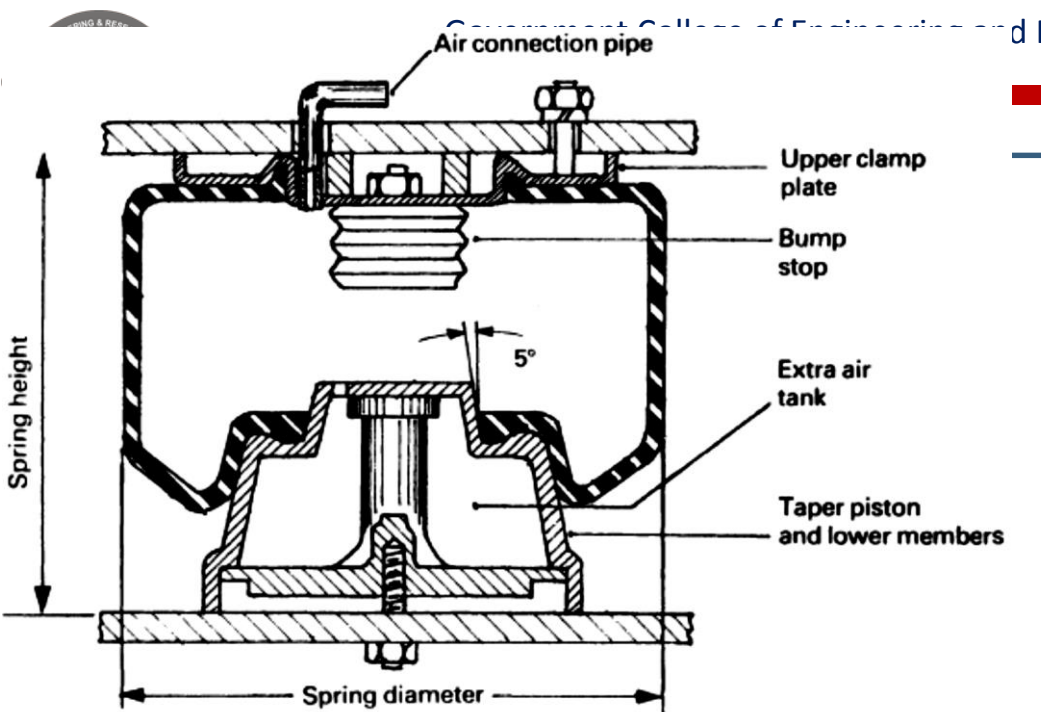

Rolling Lobe/Diaphragm

Involute/Double Convolute Spring

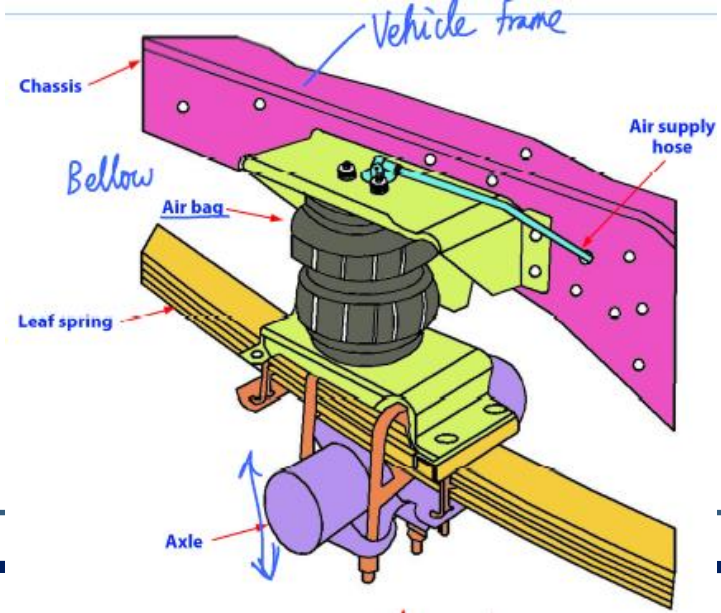

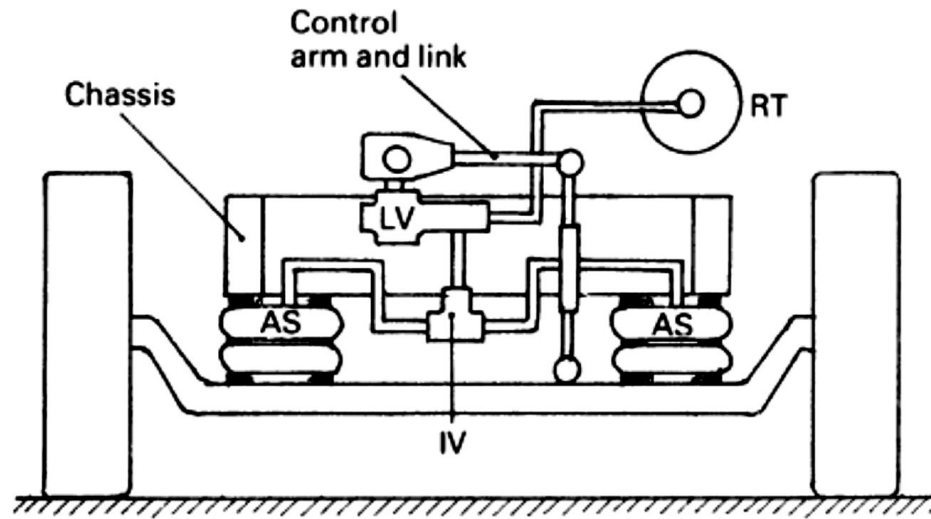



❖ Advantages

- These maintain a constant bounce frequency of vibration (Narrow band-60 to 110) whether the vehicle is laden or un-laden.
- Constant frame height is maintained.
- It gives smooth and comfort ride of the vehicle.
- The stiffness of the system increases with the increase of the deflection.

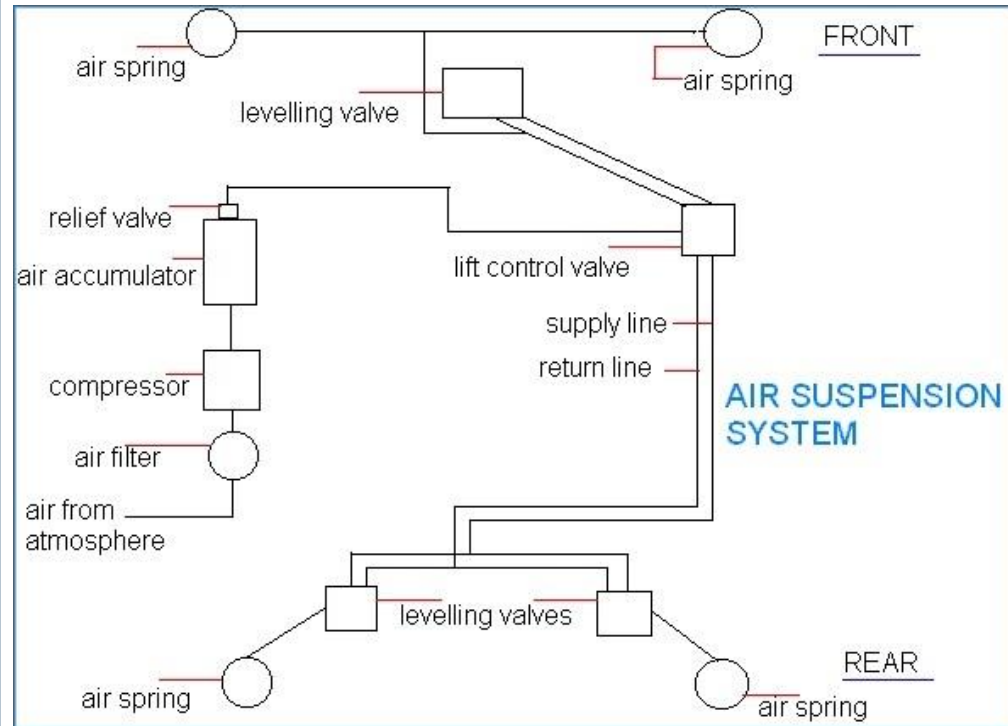



Air bag or air strut failure

- due to old age, or moisture within the air system that damages them from the inside.

Air line failure

- is a failure of the tubing which connects the air bags or struts to the rest of the air system.

- this usually occurs when the air lines, which must be routed to the air bags through the chassis of the vehicle, rub against a sharp edge of a chassis member or a moving suspension component, causing a hole to form

Compressor failure

- Primarily due to leaking air springs or air struts
- Compressor burnout may also be caused by moisture from within the air system coming into contact with its electronic parts.

Dryer failure

- which functions to remove moisture from the air system eventually becomes saturated and unable to perform that function



❖ Characteristics

❑ Effects and comparison of payload on spring frequency for various types of spring media.

- An inherent disadvantage of leaf, coil and solid rubber springs is that the bounce frequency of vibration increases considerably as the sprung spring mass is reduced.
- If a heavy goods vehicle is designed for a best ride frequency of say 60 cycles per minute when fully laden, then as this load is removed, the suspension's bounce frequency could rise approximately to 300 cycles per minute if steel or solid rubber springs are used, so that a very harsh, uncomfortable ride is experienced.
- Air springs, on the other hand, can operate over a very narrow bounce frequency range (of around 60 to 110 cycles per minute for rolling lobe air spring) for considerable changes in vehicle laden weight. Therefore, the quality of ride with air springs is uniform over a wide range of operating conditions.

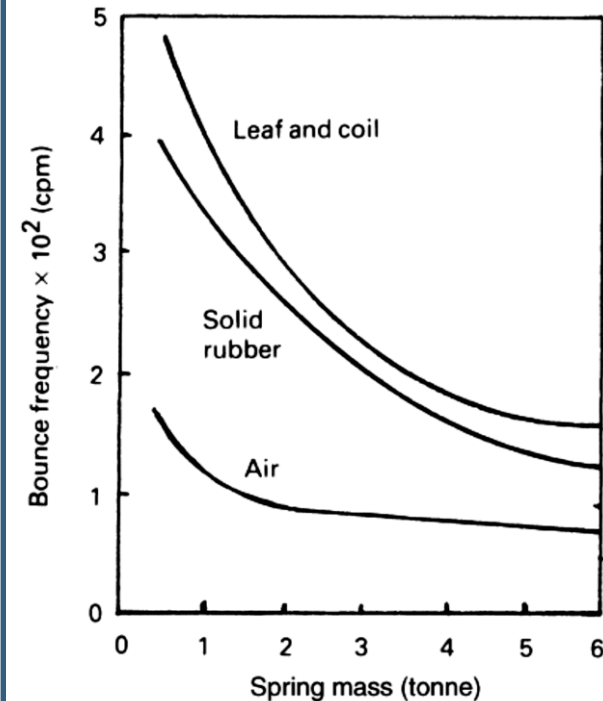



□ Effects of static load on spring height

- Steel springs have a constant stiffness and so their vertical deflection varies directly with the increase of sprung mass. On the other hand air springs have rising spring stiffness with increasing load because of the enlarging of their effective working area as the spring deflects.
- This stiffening characteristic matches well with the increased resistance required to counteract the spring deflection as it approaches the maximum bump position.

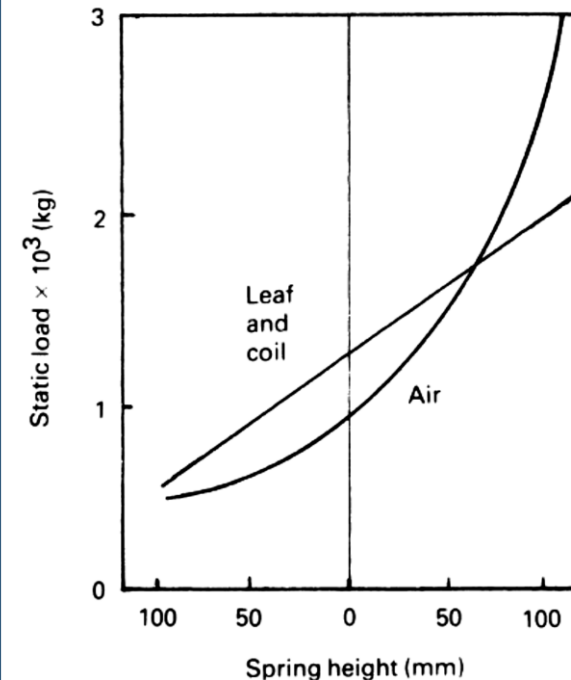



❑ Effects of static payload on spring air pressure for various spring static heights.

- The sprung mass at constant spring height is supported and maintained by increasing the internal spring air pressure directly with any rise in laden weight. These characteristics are illustrated in Fig. for three different set optimum spring heights.

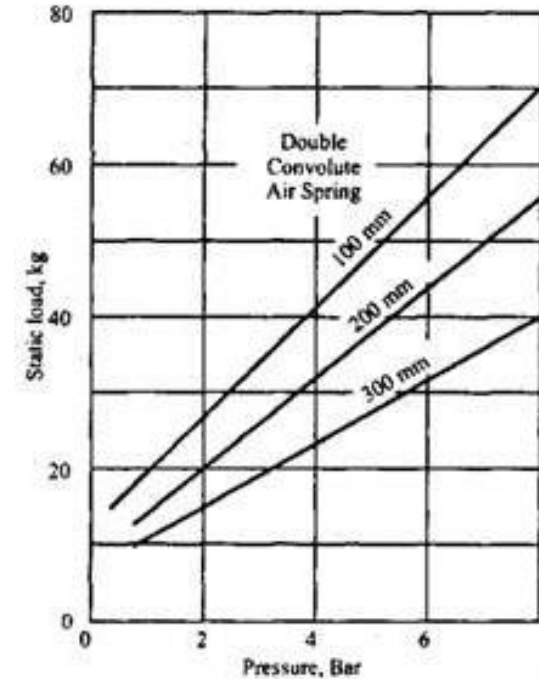



❖ Types Of Independent Suspension Systems

1. Double Wishbone suspension
2. Mac-Pherson strut type
3. Vertical guide suspension
4. Trailing link suspension
5. Swinging half axles suspension



1. Double Wishbone suspension

- It is the most common type of independent suspension system.
- The use of coil springs with a damper in front axle is common in this type of suspension.
- The upper and lower wishbone arms are pivoted to the frame member.
- The spring is placed in between the lower wishbone and the under side of the cross member.
- The vehicle weight is transmitted from the body and the cross member to the coil spring through which it goes to the lower wishbone member.

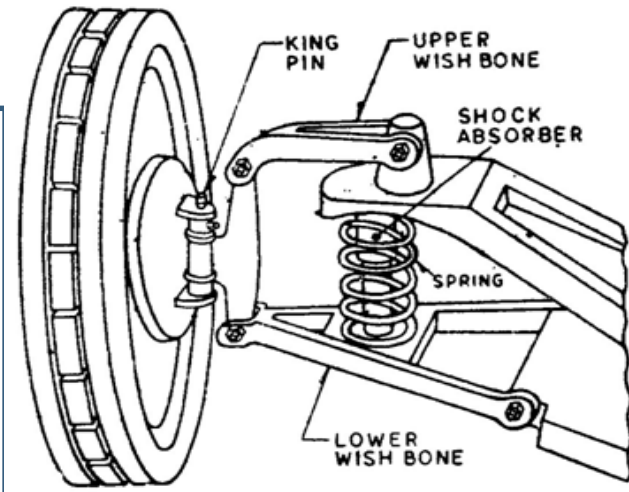

Wishbone type independent suspension.

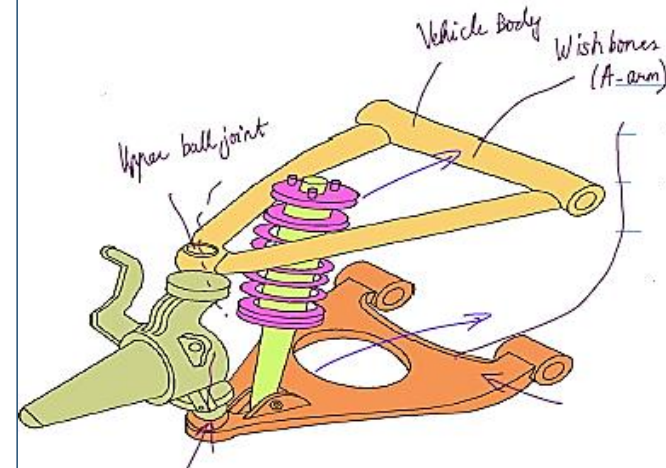



- The shock absorber is placed inside the coil spring and is attached to the cross member and to lower wishbone member.
- The wishbones not only position the wheels and transmit the vehicle load to the springs, but these also resist acceleration, braking and cornering or side forces.
- The upper wishbone arm is generally kept shorter in length than the lower ones to keep the wheel track constant and there by avoiding the excessive tyre wear.
- However a small change in the camber angle does occur with such an arrangement





- A **short long arms suspension (SLA)** is also known as an unequal length double wishbone suspension.
- The upper arm is typically an A-arm, and is shorter than the lower link which is an A-arm or an L-arm, or sometimes a pair of tension/compression arms.
- The four-bar linkage mechanism formed by the unequal arm lengths causes a change in the camber of the vehicle as it rolls, which helps to keep the contact patch square on the ground, increasing the ultimate cornering capacity of the vehicle. It also reduces the wear of the outer edge of the tire.



2. Mac-Pherson strut type

- The **MacPherson strut**, which is named after Earle S. MacPherson, who developed the suspension design in the late 1940s and patented it in 1953, is the most commonly used type.
- In this layout only the lower wishbone is used.
- A strut containing shock absorber and the coil spring also carries the stub axle on which the wheel is mounted.

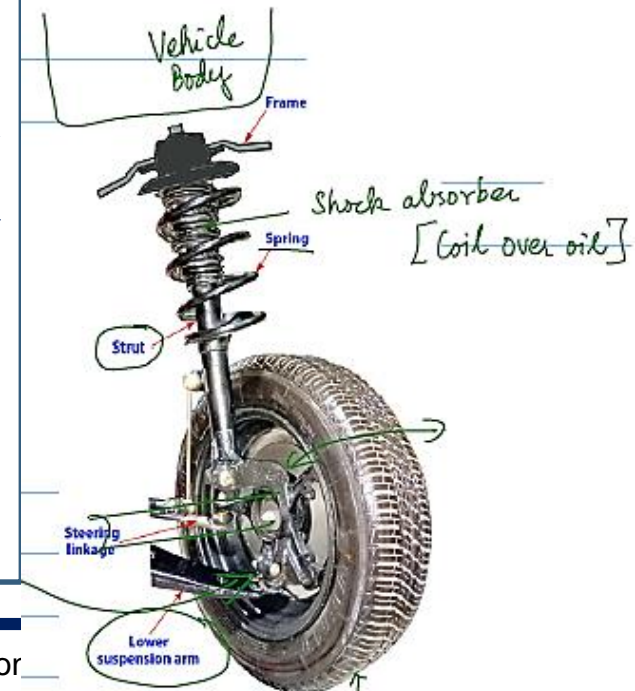
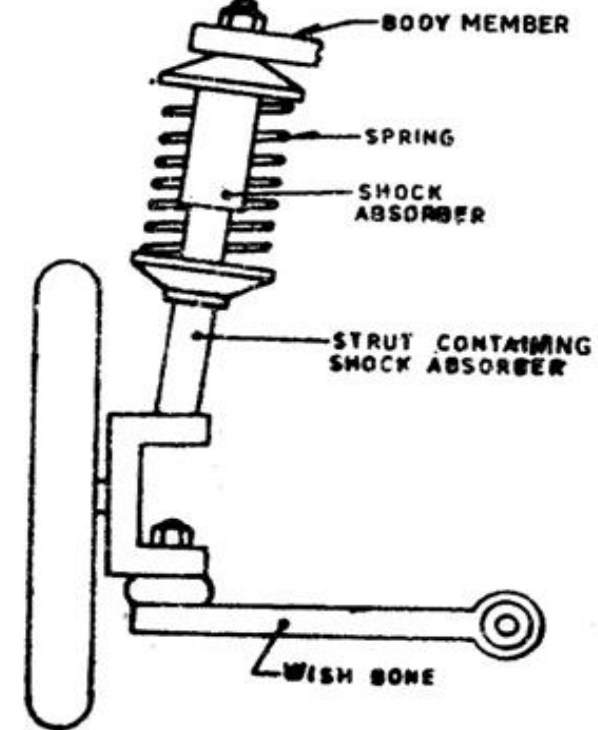



- The wishbone is hinged to the cross member and positions the wheel as well as takes the accelerating, braking and side forces.
- This system is simpler in construction
- The camber angle does not tend to change as the wheel moves up and down.
- This system will give maximum room in the engine compartment and therefore commonly used in the front wheel drive cars.
- This system with an anti roll bar provides increased road safety, improve ride comfort, light and self stabilizing steering.

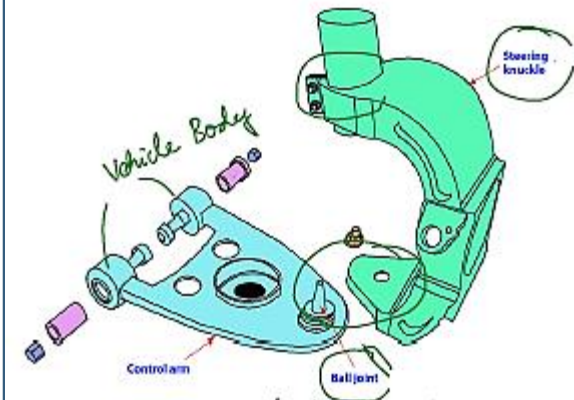



3. Vertical guide suspension

- In this suspension the king pin is directly attached to the cross member of the frame.
- It can slide up and down as shown corresponding to the motion of the wheel and there by compressing or elongating the springs.
- In this type, the wheel track, wheel base and wheel altitude remain unchanged.
- But the system is having the disadvantage of less stability.

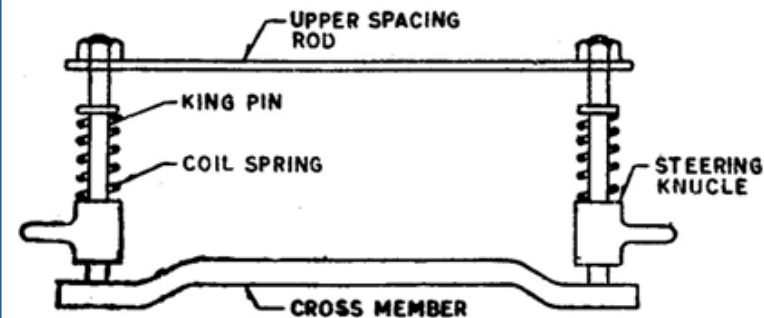



❖ **Swing Arm Suspension:**

- In this type of suspension the wheels are rigidly mounted on the triangular transverse A wishbone, which are pivoted on their ends to the chassis member at the center of the car.
- The coil springs and shock absorbers are mounted top of swing arm members near to outer ends
- It is very simple in construction but the main disadvantage is the up and down movement of the wheel causes the camber angle to vary.
- Each driveshaft has one UJ mounted inboard with its centre aligned with that of swing arm.



- Any increase in static load cause the swing arm to dip which causes the negative camber of wheels and also changes wheel track width.
- During Cornering, the inner and outer wheels become cambered negatively and positively respectively.

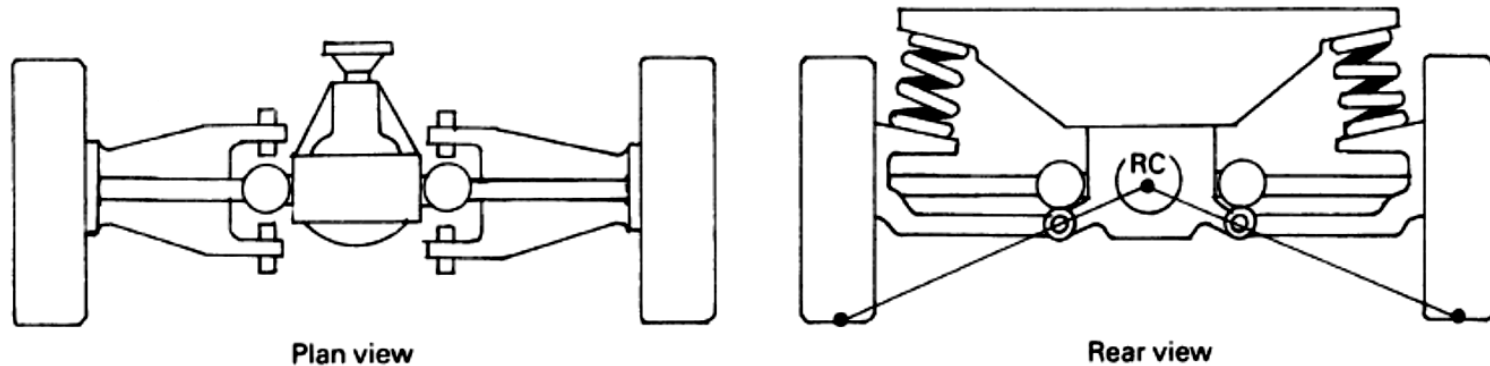



4. Trailing Arm/Link suspension

- A **trailing-arm suspension**, sometimes referred as **trailing-link** is a vehicle suspension design in which one or more arms (or "links") are connected between (and perpendicular to and forward of) the axle and a pivot point (located on the chassis of a motor vehicle).
- It is typically used on the rear axle of a motor vehicle.

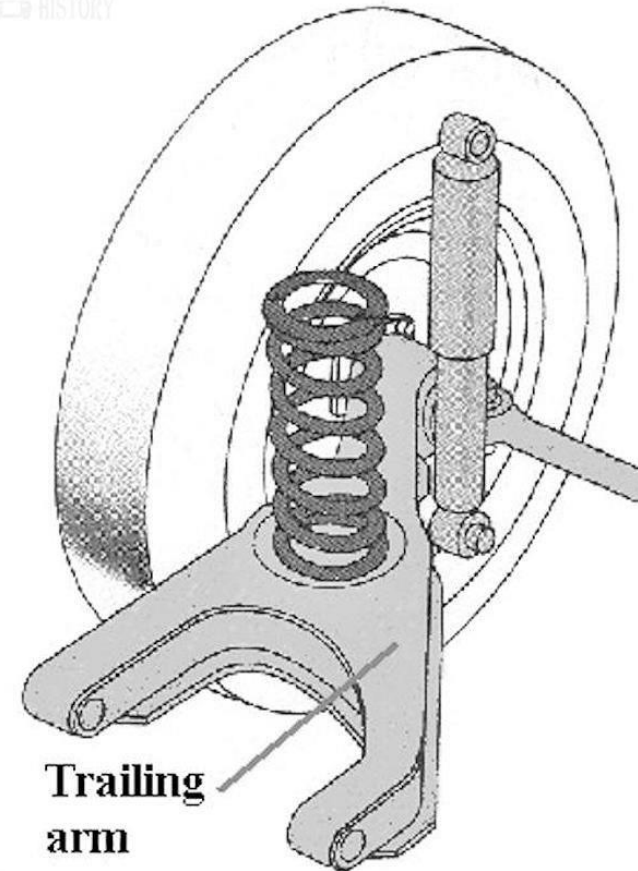

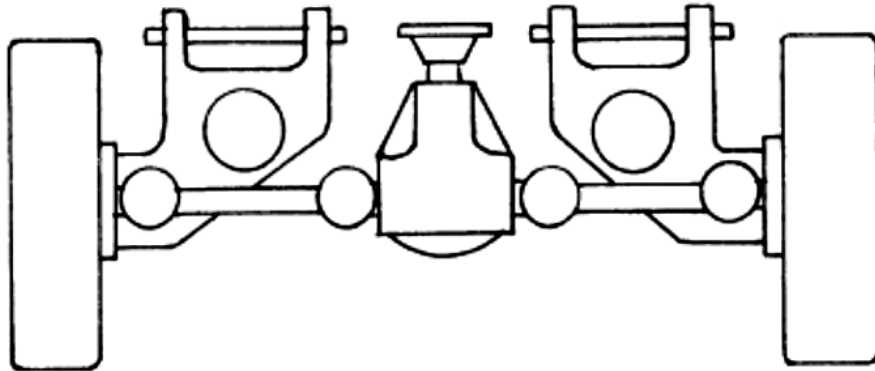

Plan view

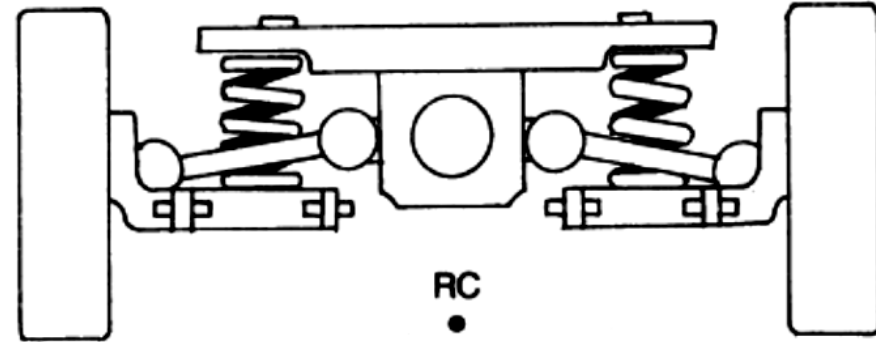

Rear view

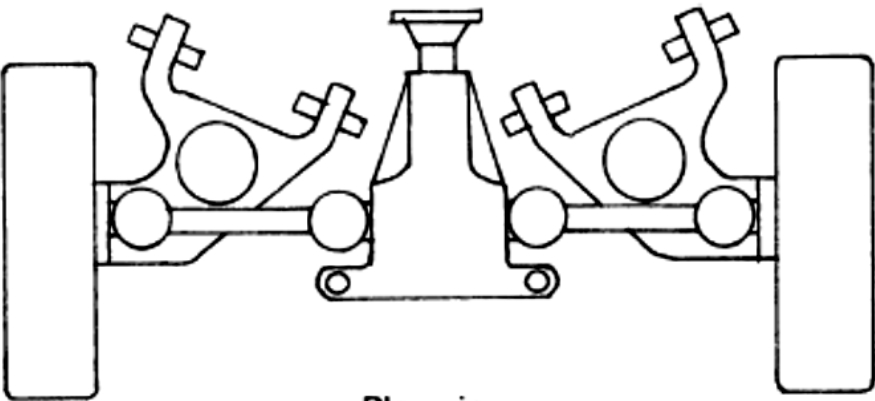

Plan view

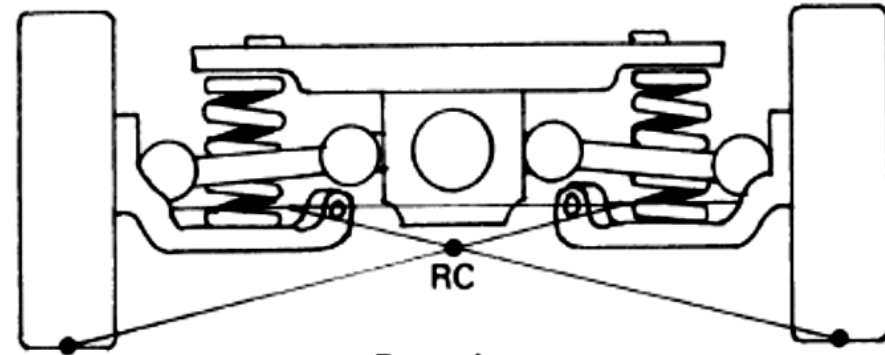

Rear view

Trailing Arm

Semi-Trailing Arm



- Trailing-arm designs in live axle setups often use just two or three links and a Panhard rod to locate the wheel laterally. A trailing arm design can also be used in an independent suspension arrangement. Each wheel hub is located only by a large, roughly triangular arm that pivots at one point, ahead of the wheel. Seen from the side, this arm is roughly parallel to the ground, with the angle changing based on road irregularities
- A semi-trailing arm suspension is a simple independent rear suspension system for automobiles where each wheel hub is located only by a large, roughly triangular arm that pivots at two points. Viewed from the top, the line formed by the two pivots is somewhere between parallel and perpendicular to the car's longitudinal axis; it is generally parallel to the ground. Trailing-arm and multilink suspension designs are much more commonly used for the rear wheels of a vehicle where they can allow for a flatter floor and more cargo room.

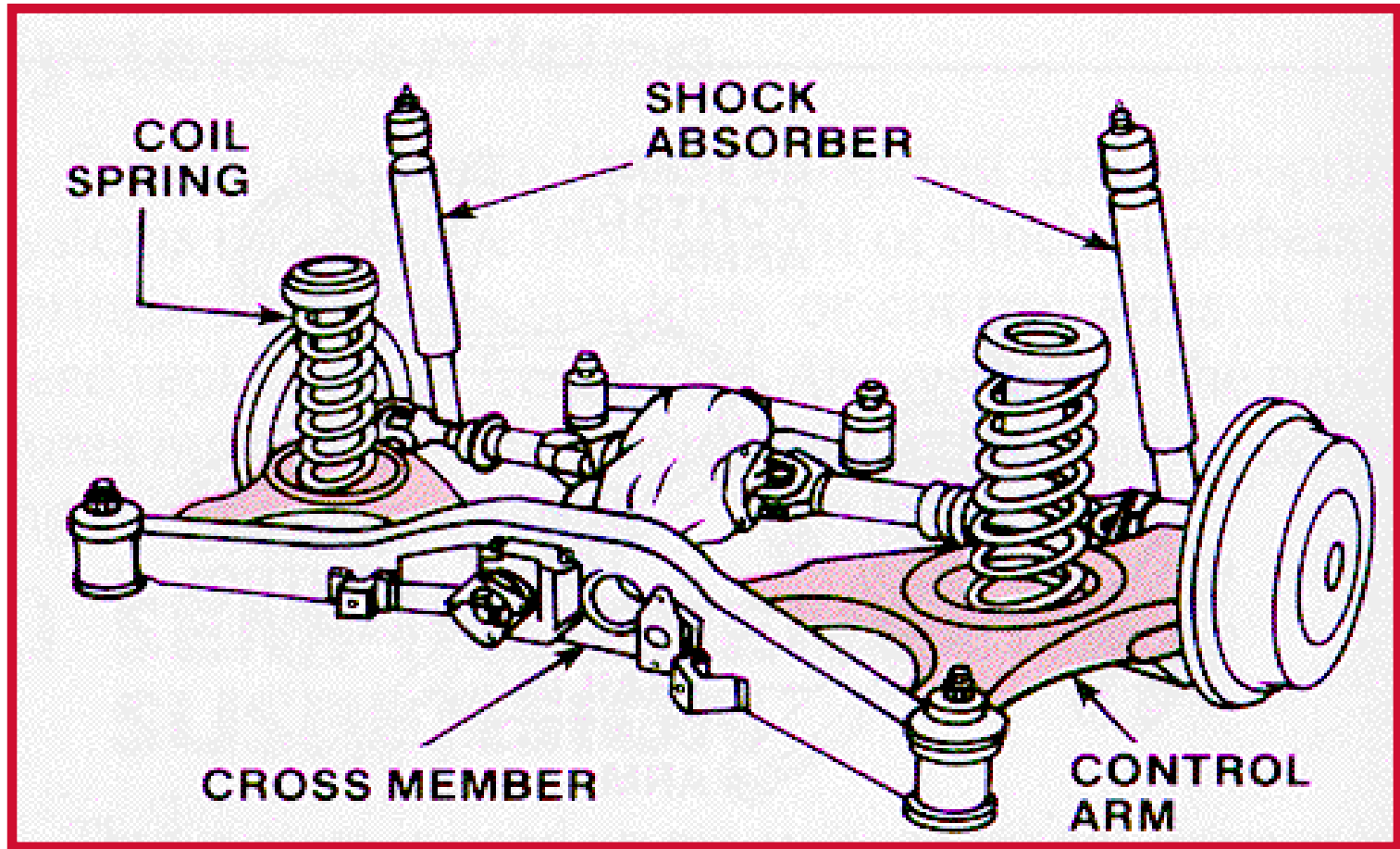



❖ Multi-link Suspension:

- A multi-link suspension is a type of vehicle suspension design typically used in independent suspensions, using three or more lateral arms, and one or more longitudinal arms. These arms do not have to be of equal length, and may be angled away from their 'obvious' direction.
- Typically, each arm has a spherical joint (ball joint) or rubber bushing at each end. Consequently, they react on loads along their own length, in tension and compression, but not in bending.

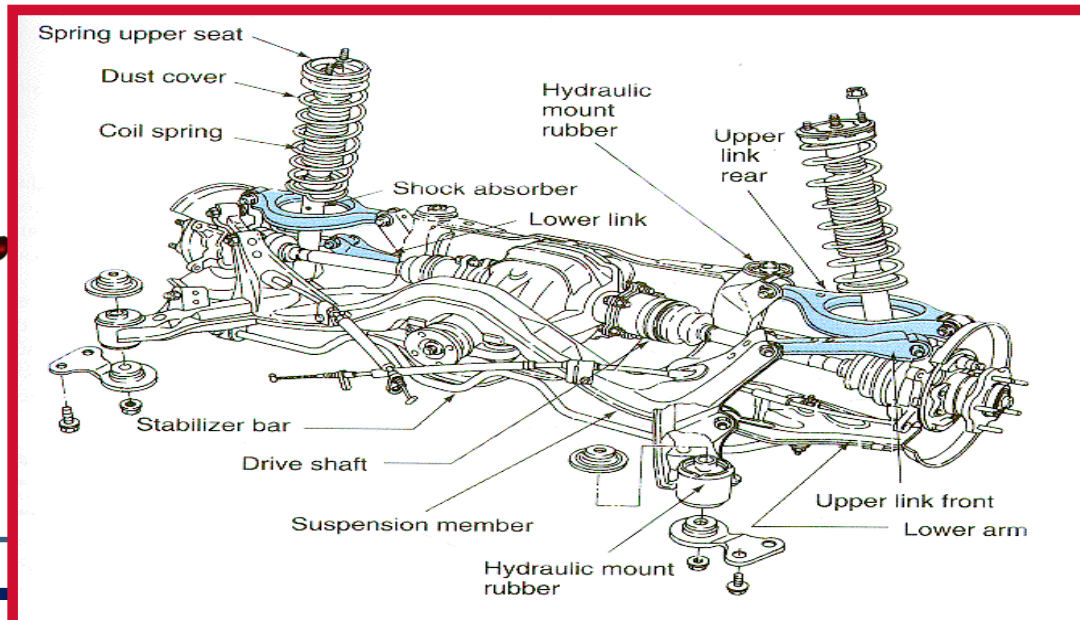
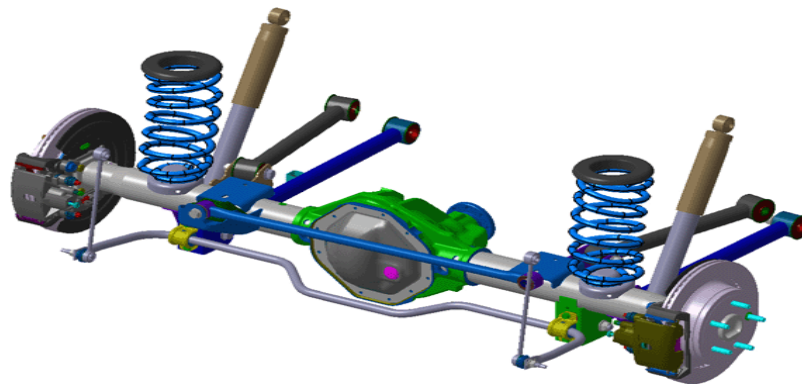



- Some multi-links do use a trailing arm or wishbone, which has two bushings at one end. On a front suspension one of the lateral arms is replaced by the tie-rod, which connects the rack or steering box to the wheel hub
- Multi-link suspension allows the auto designer the ability to incorporate both good ride quality and good car handling in the same vehicle.
- In its simplest form the multi-link suspension is orthogonal - that is, it is possible to alter one parameter in the suspension at a time, without affecting anything else.
- This is in direct contrast to a double wishbone suspension where moving a hard-point or changing a bushing compliance will affect two or more parameters.



❖ Anti-Roll Bar or Stabilizer Bar or Sway Bar

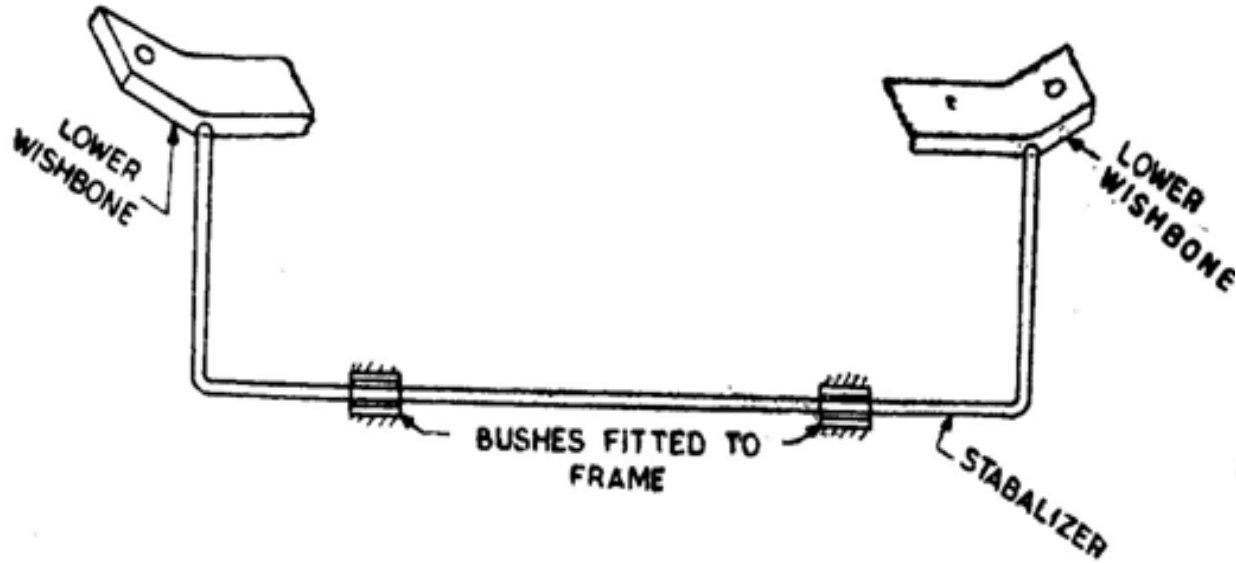

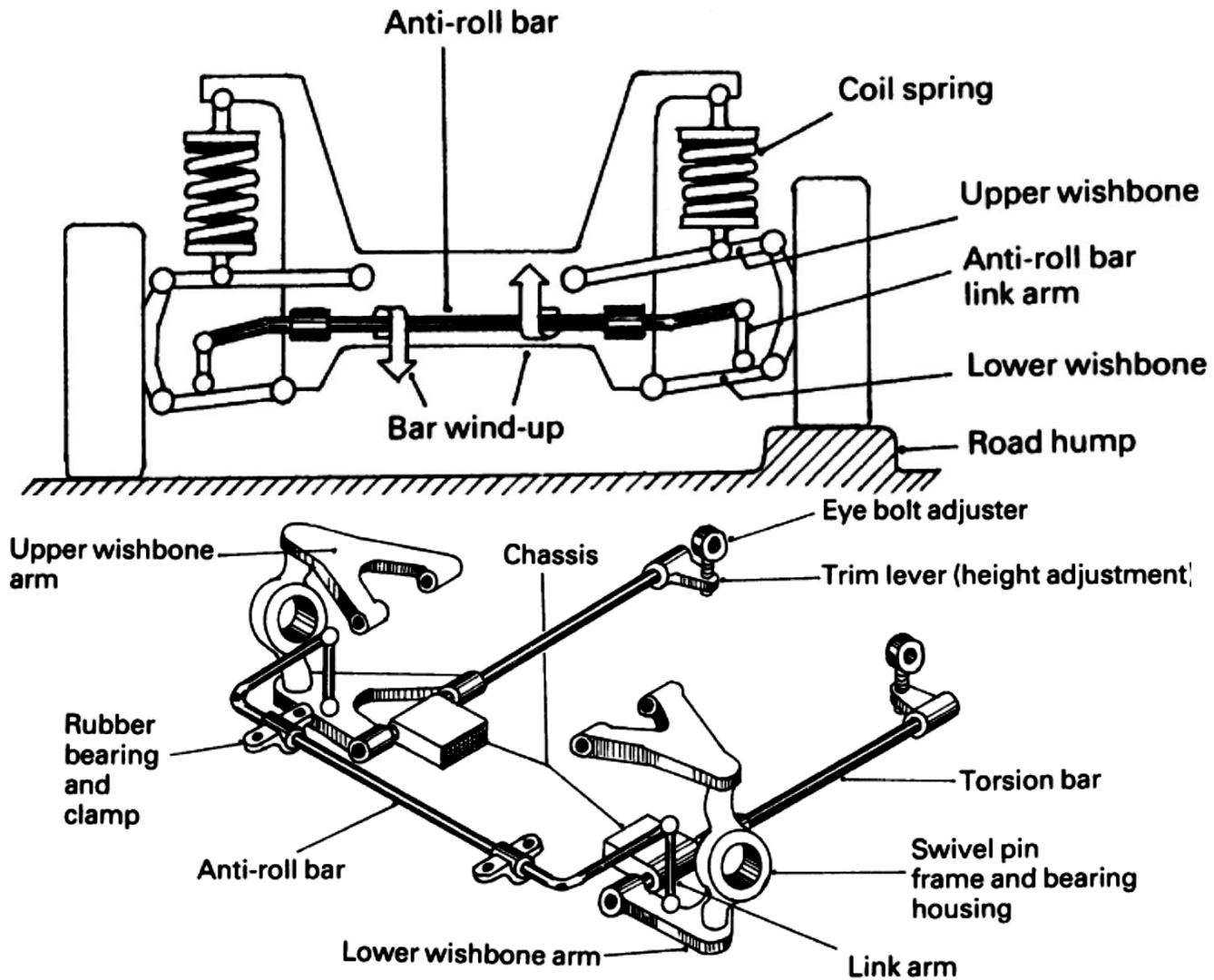

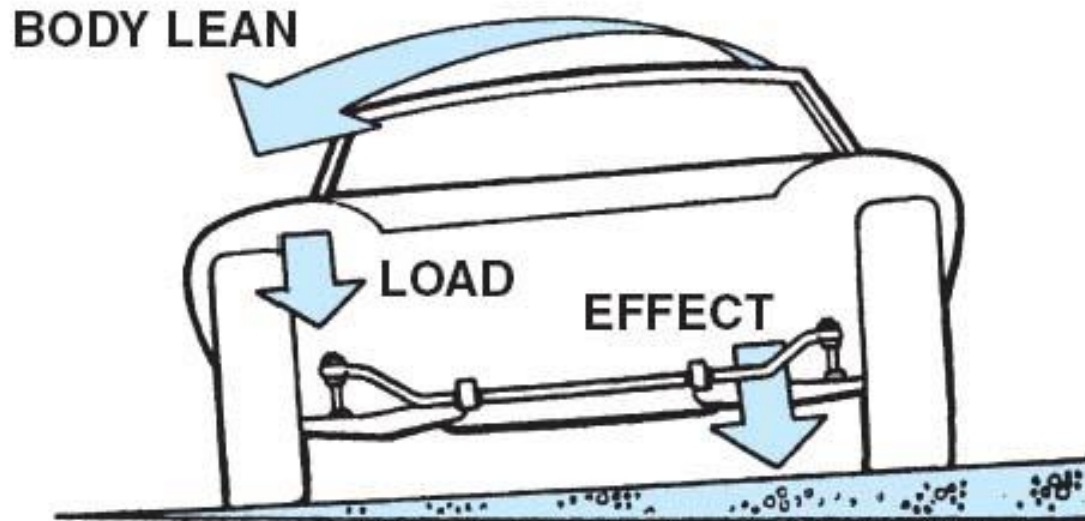
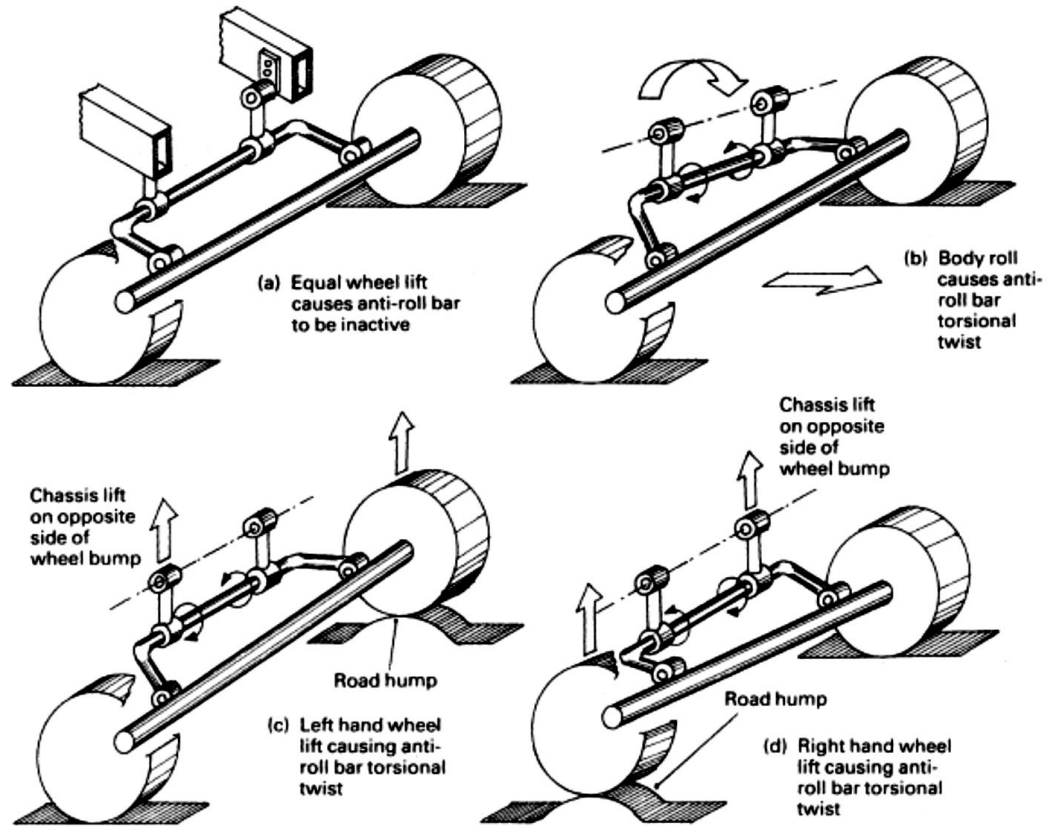

FIGURE 5-41 As the body of the vehicle leans, the stabilizer bar is twisted. The force exerted by the stabilizer bar counteracts the body lean.
(Courtesy of Moog)



- When a vehicle pass over a bump, one road wheel may deflect more than the other and there will be a tendency for the vehicle to roll.
- To reduce this tendency a stabilizer or anti-roll bar is used in the form of a torsion bar.
- The stabilizer ends are connected to the rear leaf springs or the lower wishbones and is supported by two bearings, which are fixed to the side members of the frame.
- By this arrangement when one road wheel spring is deflected than the other, the energy which would have caused the rolling of the vehicle is converted into the twisting of the torsion bar.



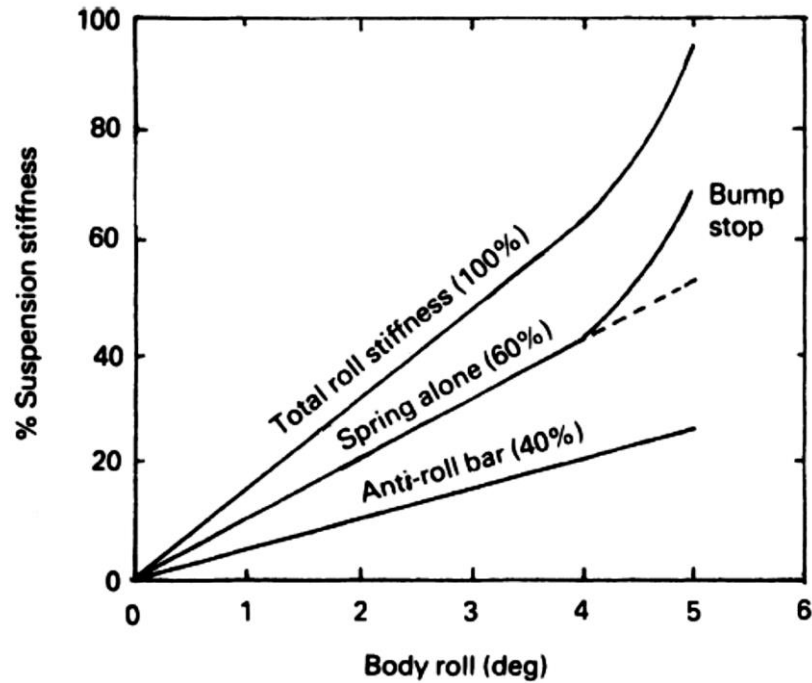

Fig. 10.37 Relationship of body roll and suspension spring and anti-roll bar stiffness

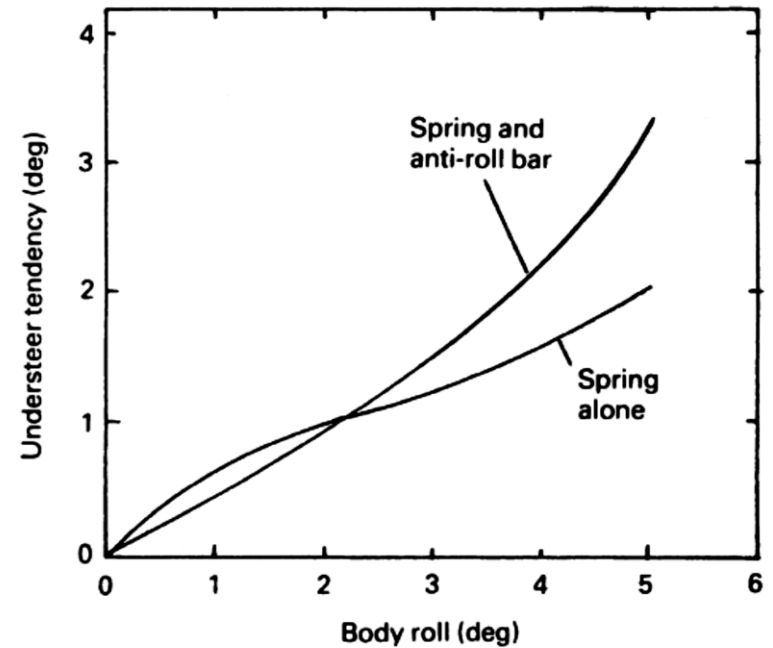
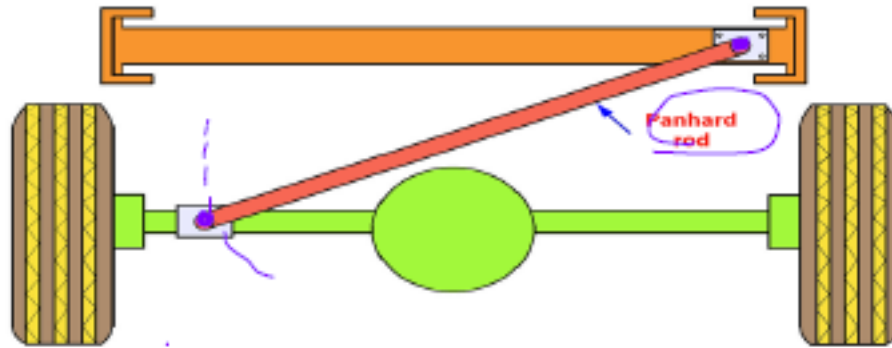

Fig. 10.38 Relationship of body roll and the understeer tendency with and without an anti-roll bar



❖ Panhard Rod:

- Prevents/Reduces side to side/ Lateral movement of the dependent rear axle while cornering and on irregular roads.
- One end of the panhard rod is attached to the axle and the other end is attached to the vehicle body at laterally opposite side.



❖ Hydro-elastic Suspension:

- In this system a displacer unit is fitted at each of the four wheels. The displacer units are interconnected by means of fluid.
- In the displacer unit, rubber is used as a spring whereas fluid under pressure acts as damping medium.
- The stem is connected to the wheel through a suitable linkage so that its movement is proportional to the up and down movement of the wheel.

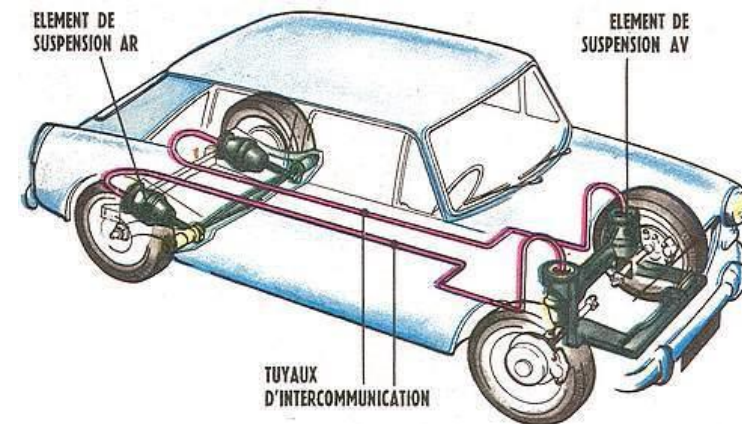
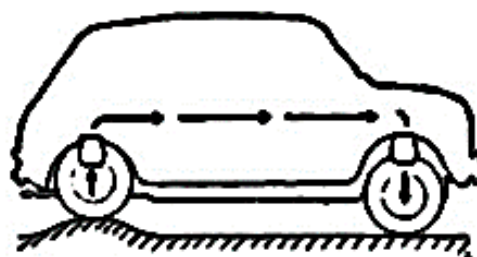
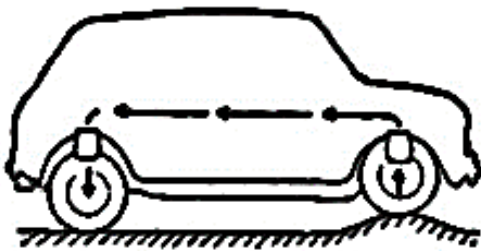

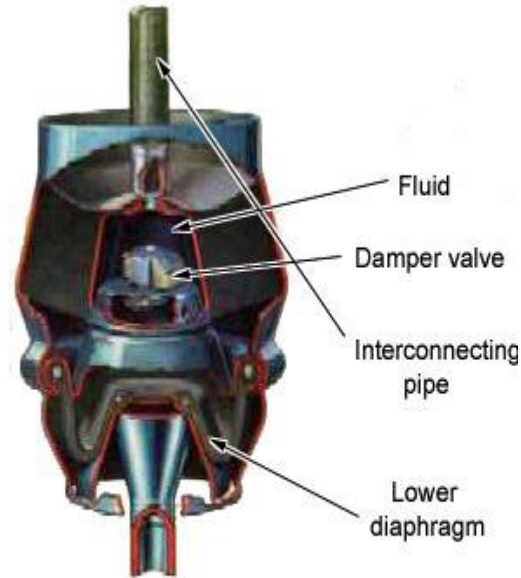
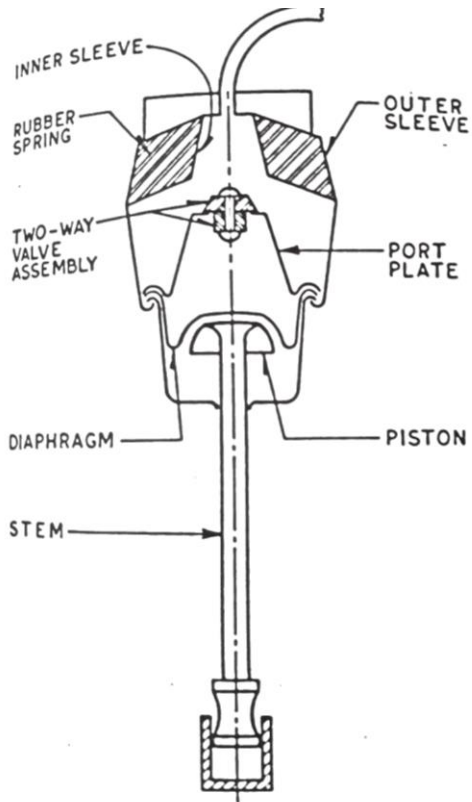

Hydrolastic displacer





- This suspension is intended to improve the vehicle's resistance to pitch, the tendency of the body to oscillate in a fore-and-aft direction when the front springs are compressed and the rear springs are expanded simultaneously.
- The continuous forward and backward pitching motion provides a most uncomfortable ride, which may become serious when the frequency of vibration of front and rear springs is the same.
- The interconnection is carried out using two pipes. One pipe links the left-hand side units together and the other on the right-hand side. The system is pressurized with an **anti-freeze** liquid after removing air.



- Each displacer unit contains a rubber spring; metal separating member, which holds two way rubber damper valves; rubber diaphragm attached to the suspension linkage, which holds the wheel; and a metal body, which is secured to the frame of the vehicle.
- A sudden upward movement of the front wheel causes the diaphragm to displace the liquid through the damper.
- This action in turn forces liquid along the pipe to the rear unit where it moves the diaphragm and raises the rear of the car to the level of the front.
- When the front wheel descends, the liquid returns and the vehicle comes to its normal riding position.
- During this sequence the liquid has to pass the damper valve in each unit, and the restriction to liquid flow at the valves and in the pipelines damps out the tendency of pitch oscillation.



- When a vehicle is cornering, the body of the vehicle tilts or rolls outwards due to centrifugal force.
- This tilting action is apparent when 'soft' conventional springs are used. The hydrolastic system is 'soft' during movement of a single wheel, but if the two outside suspension units are loaded during cornering, a stiffening of the hydrolastic system occurs.
- Under this type of loading **displacement of the fluid from one unit to the other does not occur**. Instead the increased liquid pressure deflects the rubber springs, which provide a marked resistance to the tilt of the body.
- During bouncing of the vehicle four wheels deflect at the same time. To resist this motion all the hydrolastic units perform in the similar way as to react to roll.



Hydra-gas Suspension System:

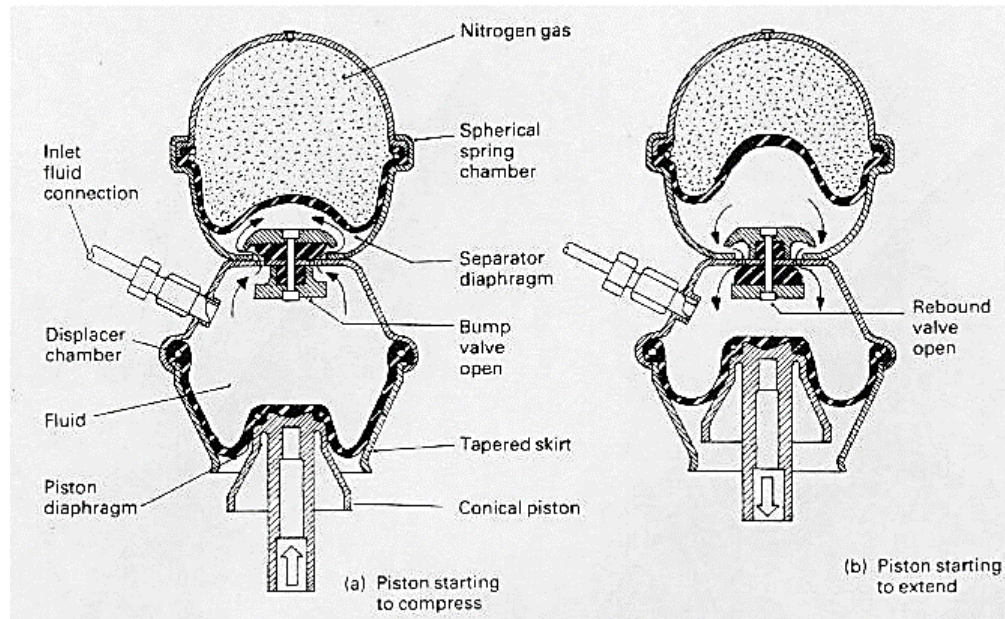



- The spring unit is comprised of a nitrogen filled spherical spring chamber welded to a double conical shaped displacement chamber.
- A hydraulic damper in the form of a pair of rubber compression blocks separates both spherical spring and displacer chambers, its function being to control the flow of fluid as it passes to and fro between the two chambers.
- The displacer chamber is sealed at its lower end by a load absorbing nylon reinforced rubber diaphragm (piston diaphragm) which rolls between the conical piston and the tapered displacer chamber skirt as the suspension deflects up and down when the wheels pass over any irregularities on the road surface.
- Within the spherical chamber is a butyl-rubber diaphragm (separator diaphragm) which separates the sphere into a nitrogen charged (17.5 bars) upper region (the spring media) which is sealed for life, and the lower region which is filled with fluid.



- Initially fluid is pumped into the displacer chamber until it reaches the nitrogen charging pressure. Then it will compress and lift the separator diaphragm off the bottom of the sphere.
- Since the gas and fluid pressures are equal, the separator diaphragm is not subjected to heavy loads, in fact it only functions as a flexible wall to keep the gas and fluid apart.
- A water based fluid containing 50% industrial alcohol and a small percentage of anti-corrosion additive is pumped into the system to a pressure of 23 bars with the car in a un-laden state, this being the condition in which the car's body to ground height is checked.
- One advantage in using the rolling diaphragm type of displacer is that a water based fluid can be utilized as opposed to an oil which would not have such stable viscosity characteristics.



- The effective area of the piston compressing the fluid is that projected area of the displacer diaphragm which is not supported by the internal tapered skirt of the displacer chamber.
- Therefore, as load on the displacer piston increases, and the piston is pushed further into the chamber, less of the displacer diaphragm will be supported by the chamber's skirt and more will form part of the projected effective piston area.
- The consequence of the diaphragm piston pushing up within the displacer chamber is that the load bearing area of the piston is increased due to the diaphragm rolling away from its supporting tapered chamber skirt.
- As a result the resistance offered by the fluid against the upward movement of the piston rises.



- In other words, due to the tapered chamber's skirt, the spring rate (stiffness) increases in proportion to the spring's deflection.
- The progressive action of the rubber valve between the two chambers provides for a measure of damping which slows down bump and rebound movements caused by the impact of the tyre on very bumpy roads.

❖ Shock Absorber:

- Shock absorbers are used on all conventional suspension systems to dampen and control the motion of the vehicle's springs. Without shock absorbers (dampers), the vehicle would continue to bounce after hitting bumps.

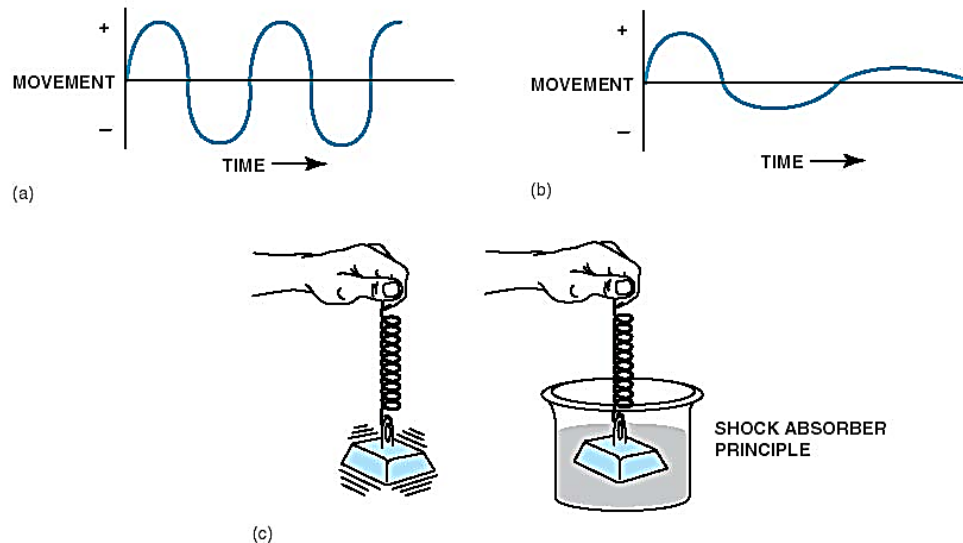

FIGURE 5-44 (a) Movement of the vehicle is supported by springs without a damping device. (b) Spring action is dampened with a shock absorber. (c) The function of any shock absorber is to dampen the movement or action of a spring, similar to using a liquid to control the movement of a weight on a spring.



- The major purpose of any shock or strut is to control ride and handling. Standard shock absorbers do not support the weight of a vehicle.
- The springs support the weight of the vehicle; the shock absorbers control the actions and reactions of the springs. Shock absorbers are also called **dampers**.

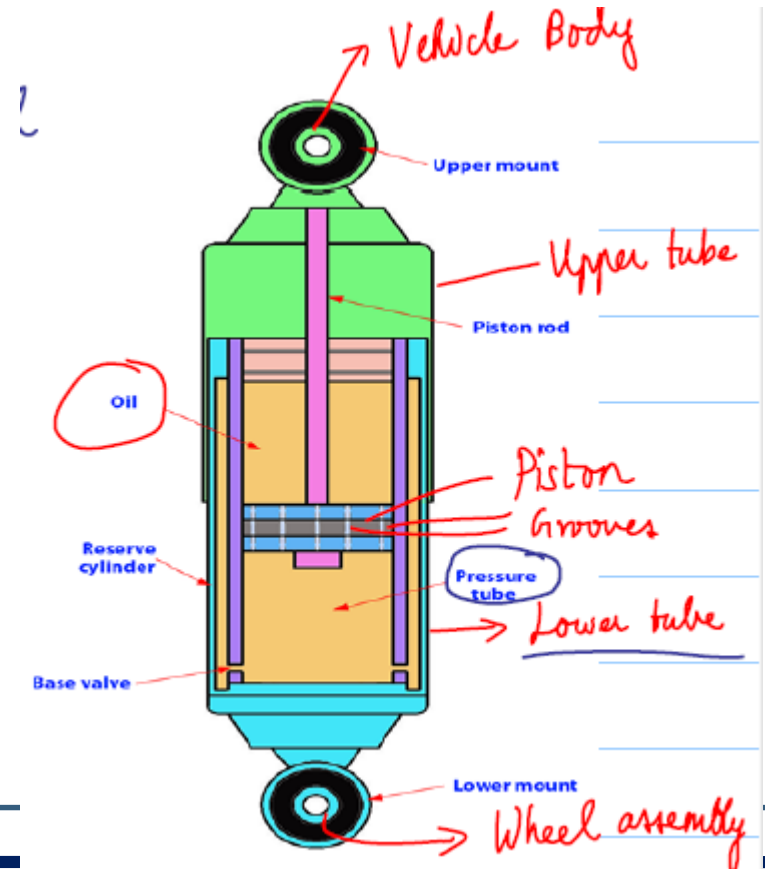
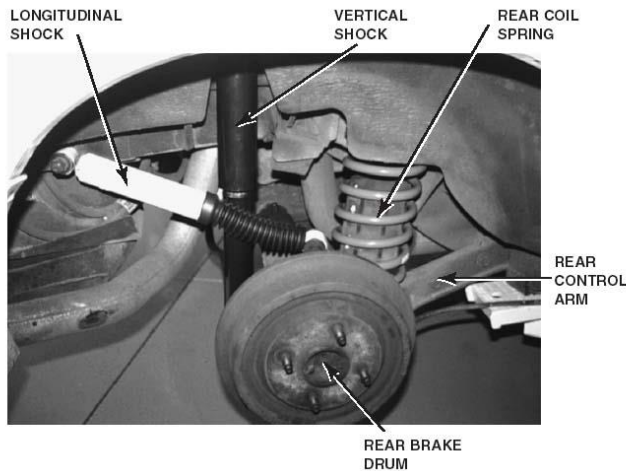

FIGURE 5-46 Some vehicles such as this Ford Mustang use four shock absorbers on the rear suspension. The vertical shock absorbers control vertical body movement and react with the rear coil springs. The longitudinal shocks help control the rear axle during acceleration and deceleration.



- As a wheel rolls over a bump, the wheel moves toward the body and compresses the spring(s) of the vehicle.
- As the spring compresses, it stores energy. The spring then releases this stored energy, causing the body of the vehicle to rise (rebound).

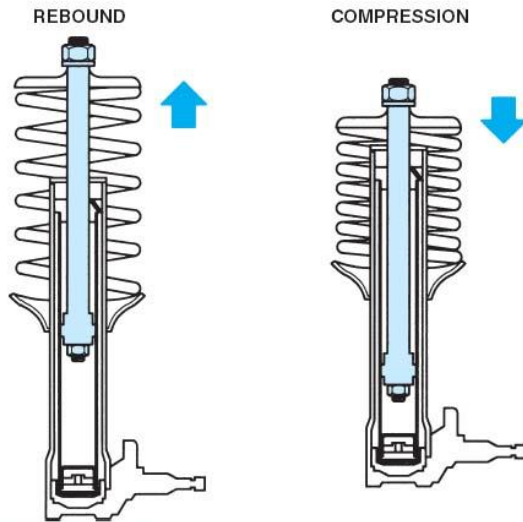

FIGURE 5-47 When a vehicle hits a bump in the road, the suspension moves upward. This is called compression. Rebound is when the spring (coil, torsion bar, or leaf) returns to its original position.

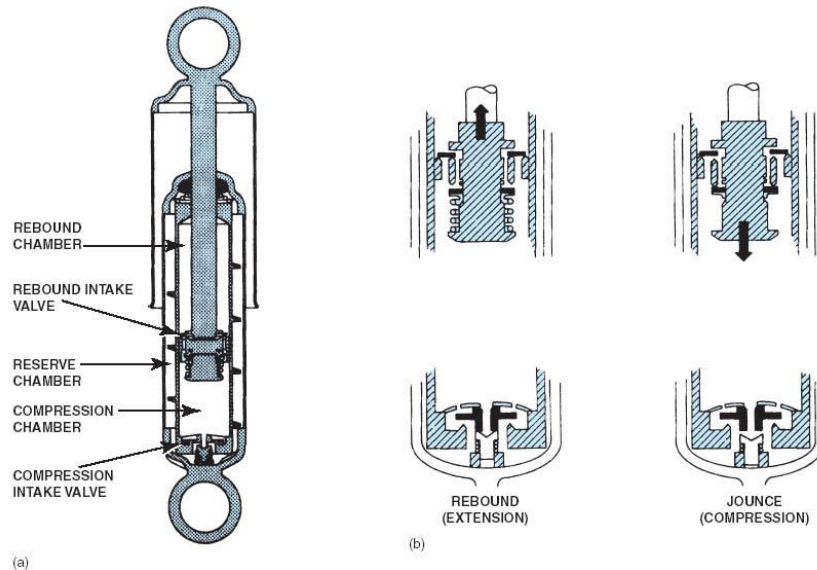

FIGURE 5-48 (a) A cutaway drawing of a typical double-tube shock absorber. (b) Notice the position of the intake and compression valve during rebound (extension) and compression.

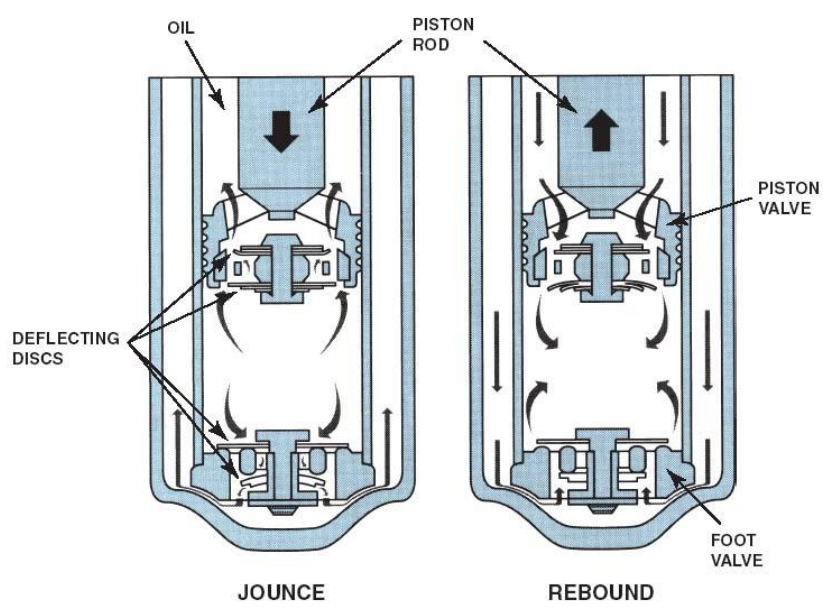
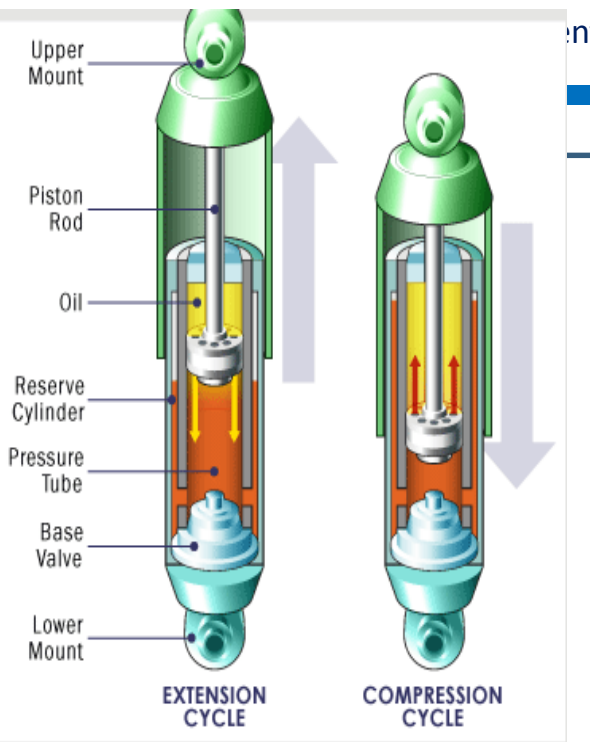
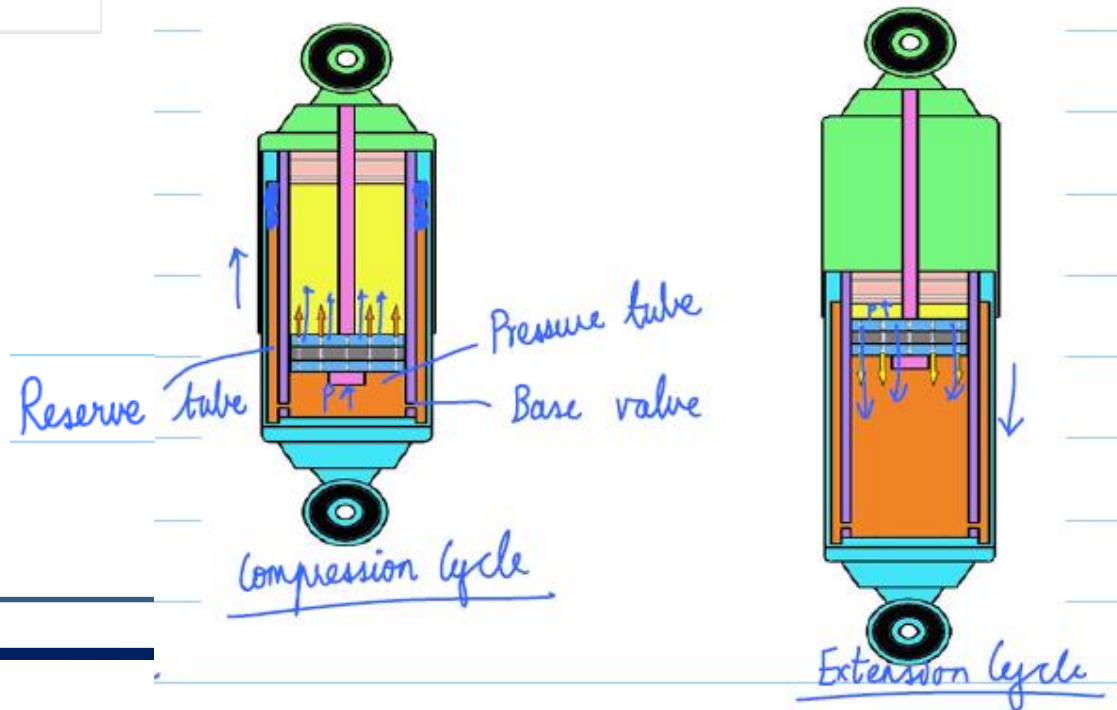

FIGURE 5-49 Oil flow through a deflected disc-type piston valve. The deflecting disc can react rapidly to suspension movement. For example, if a large bump is hit at high speed, the disc can deflect completely and allow the suspension to reach its maximum jounce distance while maintaining a controlled rate of movement.





- ❑ When the shock absorber is under compression
 - Fluid in the cylinder passes upwards through the restricted valves of the piston
 - At the same time the fluid passes down through a small valve of the cylinder tube
 - Due to this arrangement the piston is able to move against the resistance of the fluid, thus the shock is absorbed.

- ❑ When the shock absorber is under tension:
 - Liquid from the top portion of piston is forced downward through the piston valves
 - At the same time the fluid enters through the valve at the bottom of the cylinder tube.
 - The lengthening of shock absorber is thus made very slow, since it has to overcome the resistance of the fluid



❖ Mono Tube Shock Absorber:

- Does not have reserve tube.
- A floating piston separates the hydraulic fluid from the nitrogen gas.

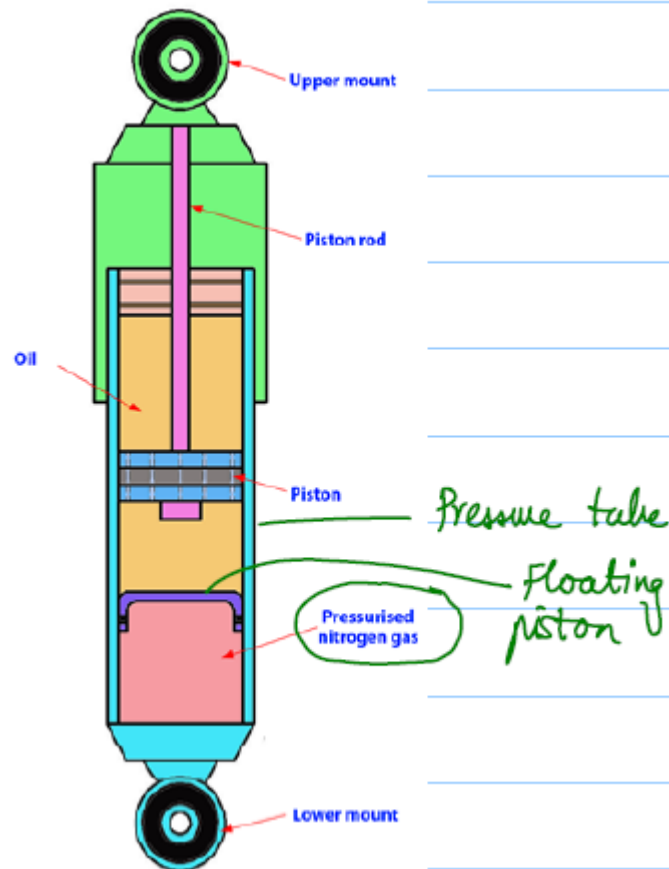



❖ **Classification of Suspension Systems:**

A. From the perspective of performance.

1. Passive Suspension

- Has a spring and a shock absorber with fixed stiffness and damping characteristics.
- Represents a compromise between ride comfort and road holding.

2. Semi-Active Suspension

- Uses a variable damping element such as an adjustable twin tube viscous damper in which the damping characteristics can be changed by varying the area of the orifice in the piston/damper.

3. Active Suspension

- Uses an electronically controlled actuator to provide improved performance.
- Higher cost and complexity, actuator bandwidth.



❖ Active Suspension:

An ideal suspension system should be able to perform numerous functions that are listed below;

1. To absorb the bumps and rebounds imposed on the suspension from the road.
2. To control the degree of body roll when cornering
3. To maintain the body height and to keep it on an even keel between light and full load conditions.
4. To prevent body dive and squat when the car is rapidly accelerated or is braked
5. To provide the comfortable ride over rough roads yet maintain suspension firmness for good steering response.
6. To isolate small and large round irregularities from the body at both high and low vehicle speed



- These demands on a conventional suspension are only partially achieved as to satisfy one or more of the listed requirements may be contrary to the fulfilment of some of the other desired suspension properties
- For example, providing a soft springing for light loads will excessively reduce the body height when the vehicle is fully laden or conversely, stiffening the springing to cope with heavy loads will produce a harsh suspension under light load conditions.
- Accordingly, most conventional suspensions may only satisfy the essential requirements and will compromise on some of the possibly less important considerations.



- An active suspension will have built into design means to satisfy all of the listed demands; however, even then it may not be possible due to limitations of a design and cost to meet and overcome all of the inherent problems experienced with vehicle suspension.
- Thus it would be justified to classify most suspension which have some form of height leveling and anti-body roll features as only semi-active suspensions.
- For an active suspension to operated effectively various sensors are installed around the vehicle to monitor changing driving conditions; the electrical signs provided by these sensors are continuously fed to the input of an electronic control unit.
- The ECU evaluates and processes the data supplied by the sensors on the changing speed, load and driving conditions imposed on the suspension system.



List of sensors which can be used in Active Suspensions.

1. Body height sensor
2. Steering wheel sensor
3. Longitudinal acceleration sensor
4. Lateral acceleration sensor
5. Brake pressure sensor
6. Brake pedal sensor
7. Acceleration pedal sensor
8. Load sensor
9. Vehicle speed sensor
10. Mode selector



- An active suspension system has the ability to store, dissipate and to introduce energy to the system.
- It may vary its parameters depending upon operating conditions and can have knowledge other than the strut deflection the passive system is limited to

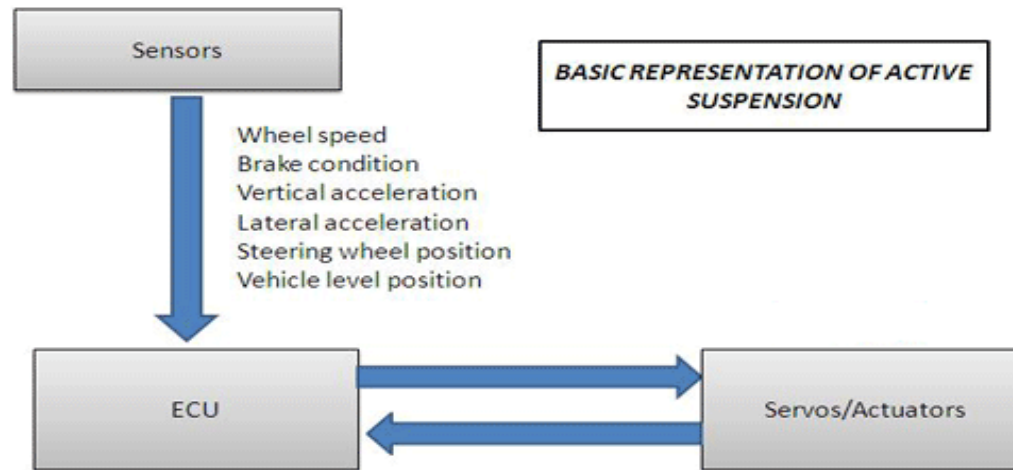



Types:

Active Suspension

1. Electronically controlled Hydraulic actuated
2. Electromagnetic recuperative

Semi-active or adaptive suspension

1. Semi-active Hydro-gas suspension
2. Electronically controlled hydro-gas suspension.
3. Electronically controlled air suspension